



Office of the City Manager

INFORMATION CALENDAR
November 21, 2023

To: Honorable Mayor and Members of the City Council
From: Dee Williams-Ridley, City Manager
Submitted by: Jordan Klein, Director, Planning and Development Department
Subject: LPO NOD: 803 Delaware Street, LMSAP2023-0002

INTRODUCTION

The attached Landmarks Preservation Commission Notice of Decision (NOD) is presented to the Mayor and City Council pursuant to Berkeley Municipal Code/Landmarks Preservation Ordinance (BMC/LPO) Section 3.24.240.A, which requires that “a copy of the Notice of Decision shall be filed with the City Clerk and the City Clerk shall present said copy to the City Council at its next regular meeting.”

CURRENT SITUATION AND ITS EFFECTS

The Landmark Preservation Commission (LPC/Commission) has approved a Structural Alteration Permit (SAP) for the subject City Landmark property. This action is subject to a 15-day appeal period that began on October 31, 2023, after being postponed from August 29, 2023.

BACKGROUND

BMC/LPO Section 3.24.300 allows City Council to review any action of the Landmarks Preservation Commission in granting or denying a Structural Alteration Permit. For Council to review the decision on its merits, Council must appeal the Notice of Decision. To do so, a Council member must move this Information Item to Action and then move to set the matter for hearing on its own. Such action must be taken within 15 days of the mailing of the Notice of Decision, or by November 14, 2023. Such certification to Council shall stay all proceedings in the same manner as the filing of an appeal.

If the Council chooses to appeal the action of the Commission, then a public hearing will be set. The Council must then rule on the designation within 30 days of closing the hearing, otherwise the decision of the Commission is automatically deemed affirmed.

Unless the Council wishes to review the determination of the Commission and make its own decision, the attached NOD is deemed received and filed.

At their meeting on September 12, 2023, City Council received an Information Report citing this LPC decision and announcing the conclusion of the 15-day appeal period.

However, staff postponed the appeal period to commence on October 31, 2023 in order to correct a clerical oversight in the distribution of the public notices.

ENVIRONMENTAL SUSTAINABILITY & CLIMATE IMPACTS

Landmark designation provides opportunities for the adaptive re-use and rehabilitation of historic resources within the City. The rehabilitation of these resources, rather than their removal, achieves construction and demolition waste diversion, and promotes investment in existing urban centers.

POSSIBLE FUTURE ACTION

The Council may choose to appeal the decision, in which case it would conduct a public hearing at a future date.

FISCAL IMPACTS OF POSSIBLE FUTURE ACTION

There are no known fiscal impacts associated with this action.

CONTACT PERSON

Fatema Crane, Principal Planner, Planning and Development Department, 510-981-7410

Attachments:

1: Notice of Decision – 803 Delaware Street, #LMSAP2023-0002



L A N D M A R K S
P R E S E R V A T I O N
C O M M I S S I O N

N o t i c e o f D e c i s i o n

DATE OF BOARD DECISION: July 6, 2023
DATE NOTICE MAILED: ~~August 28, 2023~~ October 30, 2023
APPEAL PERIOD EXPIRATION: ~~September 12, 2023~~ November 14, 2023
EFFECTIVE DATE OF PERMIT (Barring Appeal or Certification): ~~September 13,~~
2023 November 15, 2023¹

803 Delaware Street – Delaware Historic District

Structural Alteration Permit #LMSAP2023-0002 to legalize one projecting sign and two site lights on the exterior of a designated City Landmark within a designated historic district.

The Landmarks Preservation Commission of the City of Berkeley, after conducting a public hearing, **APPROVED** the following request:

- **Structural Alteration Permit**

APPLICANT: Amber Baker, Project Architect
Gunkel Architecture
1295 59th Street
Emeryville, CA 94608

ZONING DISTRICT: Mixed Use Residential (M-UR)

¹ Pursuant to BMC Chapter 3.24, the City Council may “certify” any decision of the LPC for review, which has the same effect as an appeal. In most cases, the Council must certify the LPC decision during the 14-day appeal period. However, pursuant to BMC Section 1.04.070, if any portion of the appeal period falls within a Council recess, the deadline for Council certification is suspended until the first Council meeting after the recess, plus the number of days of the appeal period that occurred during the recess, minus one day. If there is no appeal or certification, the Use Permit becomes effective the day after the certification deadline has passed.

LANDMARKS PRESERVATION COMMISSION
NOTICE OF DECISION
#LMSAP2023-0002
803 Delaware Street

October 30, 2023

Page 2 of 5

ENVIRONMENTAL REVIEW STATUS: Categorically exempt under the California Environmental Quality Act Guidelines, Section 15331 of the CEQA Guidelines for Historical Resource Rehabilitation.

The application materials for this project is available online at:

<https://berkeleyca.gov/construction-development/land-use-development/zoning-projects> or
<https://permits.cityofberkeley.info/CitizenAccess/Default.aspx>

FINDINGS FOR FINAL ACTION AND APPROVED PLANS ARE ATTACHED TO THIS NOTICE

COMMISSION VOTE: 8-0-0-1

YES: ADAMS, CRANDALL, ENCHILL, FINACOM, LEUSCHNER, MONTGOMERY, SCHWARTZ, TWU

NO: NONE

ABSTAIN: NONE

ABSENT: LINVILL

TO APPEAL THIS DECISION (see Section 3.24.300 of the Berkeley Municipal Code):

To appeal a decision of the Landmarks Preservation Commission to the City Council you must:

1. Submit a letter clearly and concisely setting forth the grounds for the appeal to the City Clerk, located at 2180 Milvia Street, 1st Floor, Berkeley. The City Clerk's telephone number is (510) 981-6900.
 - a. Pursuant to BMC Section 3.24.300.A, an appeal may be taken to the City Council by the application of the owners of the property or their authorized agents, or by the application of at least fifty residents of the City aggrieved or affected by any determination of the commission made under the provisions of Chapter 3.24.
2. Submit the required fee (checks and money orders must be payable to 'City of Berkeley'):
 - a. The basic fee for persons other than the applicant is \$500. This fee may be reduced to \$100 if the appeal is signed by persons who lease or own at least 50 percent of the parcels or dwelling units within 300 feet of the project site, or at least 25 such persons (not including dependent children), whichever is less. Signatures collected per the filing requirement in BMC Section 3.24.300.A may be counted towards

LANDMARKS PRESERVATION COMMISSION
NOTICE OF DECISION
#LMSAP2023-0002
803 Delaware Street
October 30, 2023
Page 3 of 5

qualifying for the reduced fee, so long as the signers are qualified. The individual filing the appeal must clearly denote which signatures are to be counted towards qualifying for the reduced fee.

- b. The fee for appeals of affordable housing projects (defined as projects which provide 50 percent or more affordable units for households earning 80% or less of Area Median Income) is \$500, which may not be reduced.
- c. The fee for all appeals by Applicants is \$2500.
3. The appeal must be received prior to 5:00 p.m. on the "APPEAL PERIOD EXPIRATION" date shown above (if the close of the appeal period falls on a weekend or holiday, then the appeal period expires the following business day).

If no appeal is received, the landmark permit will be final on the first business day following expiration of the appeal period.

NOTICE CONCERNING YOUR LEGAL RIGHTS:

If you object to this decision, the following requirements and restrictions apply:

1. If you challenge this decision in court, you may be limited to raising only those issues you or someone else raised at the public hearing described in this notice, or in written correspondence delivered to the Landmarks Preservation Commission at, or prior to, the public hearing.
2. You must appeal to the City Council within fifteen (15) days after the Notice of Decision of the action of the Landmarks Preservation Commission is mailed. It is your obligation to notify the Land Use Planning Division in writing of your desire to receive a Notice of Decision when it is completed.
3. Pursuant to Code of Civil Procedure Section 1094.6(b) and Government Code Section 65009(c)(1), no lawsuit challenging a City Council decision, as defined by Code of Civil Procedure Section 1094.6(e), regarding a use permit, variance or other permit may be filed more than ninety (90) days after the date the decision becomes final, as defined in Code of Civil Procedure Section 1094.6(b). Any lawsuit not filed within that ninety (90) day period will be barred.
4. Pursuant to Government Code Section 66020(d)(1), notice is hereby given to the applicant that the 90-day protest period for any fees, dedications, reservations, or other exactions included in any permit approval begins upon final action by the City, and that any challenge must be filed within this 90-day period.
5. If you believe that this decision or any condition attached to it denies you any reasonable economic use of the subject property, was not sufficiently related to a legitimate public purpose, was not sufficiently proportional to any impact of the project, or for any other reason constitutes a "taking" of property for public use without just compensation under the California or United States Constitutions, your appeal of this decision must include the following information:
 - A. That this belief is a basis of your appeal.

LANDMARKS PRESERVATION COMMISSION
NOTICE OF DECISION
#LMSAP2023-0002
803 Delaware Street

October 30, 2023

Page 4 of 5

- B. Why you believe that the decision or condition constitutes a "taking" of property as set forth above.
- C. All evidence and argument in support of your belief that the decision or condition constitutes a "taking" as set forth above.

If you do not do so, you will waive any legal right to claim that your property has been taken, both before the City Council and in court.

PUBLIC COMMENT:

Communications to Berkeley boards, commissions or committees are public record and will become part of the City's electronic records, which are accessible through the City's website. **Please note: e-mail addresses, names, addresses, and other contact information are not required, but if included in any communication to a City board, commission or committee, will become part of the public record.** If you do not want your e-mail address or any other contact information to be made public, you may deliver communications via U.S. Postal Service or in person to the secretary of the relevant board, commission or committee. If you do not want your contact information included in the public record, please do not include that information in your communication. Please contact the secretary to the relevant board, commission or committee for further information.

FURTHER INFORMATION:

Questions about the project should be directed to the project planner, Desiree Dougherty, at (510) 981-7431 or Ddougherty@berkeleyca.gov. All project application materials, including full-size plans, may be viewed at the Permit Service Center (Zoning counter), 1947 Center Street, 3rd Fl., during regular business hours.

ATTACHMENTS:

- 1. Findings for Final Action
- 2. Project Plans, received **FEBRUARY 28, 2023**



ATTEST: _____

Fatema Crane, Secretary
Landmarks Preservation Commission

cc: City Clerk
Applicant: Amber Baker, Architect,
Gunkel Architecture, 1295 59th Street, Emeryville, CA 94608
Property Owner: Sharon Block and Selim Aykiran, 803 Delaware Street, Berkeley,

LANDMARKS PRESERVATION COMMISSION
NOTICE OF DECISION
#LMSAP2023-0002
803 Delaware Street
October 30, 2023
Page 5 of 5

CA 94710

ATTACHMENT 1, PART 2

FINDINGS AND CONDITIONS
JULY 6, 2023

FINDINGS REQUIRED UNDER CEQA

1. The project is categorically exempt from the provisions of the California Environmental Quality Act (CEQA, Public Resources Code §21000, et seq. and California Code of Regulations, §15000, et seq.) pursuant to Section 15331 of the CEQA Guidelines (“Historic Resource Restoration/Rehabilitation”). Furthermore, none of the exceptions in CEQA Guidelines Section 15300.2 apply, as follows: (a) the site is not located in an environmentally sensitive area, (b) there are no cumulative impacts, (c) there are no significant effects, (d) the project is not located near a scenic highway, and (e) the project site is not located on a hazardous waste site pursuant to Government Code Section 65962.5.

FINDINGS RELATED TO THE SECRETARY OF THE INTERIOR’S STANDARDS

Regarding the Secretary of the Interior’s Standards (SOI) for Rehabilitation, the Landmarks Preservation Commission of the City of Berkeley makes the following findings:

1. The proposed project does not require a change of use. The property will retain its historic commercial use.
2. The project will retain the historic character of the property and will avoid removal of distinctive materials and the alteration of features that characterize the property.
3. The new signage, site lighting, and rear egress door upgrades will not resemble or replicate designs from the property’s historic period. These new features are contemporary and will not result in a false sense of historical development.
4. Changes to the property that may have acquired significance in their own right are not affected by this project.
5. Distinctive materials, features, finishes, and construction techniques, or examples of craftsmanship that characterize this property, such as display windows, transom, trim detailing and recessed entry will be substantially retained and preserved with this project.
6. As conditioned herein, if deteriorated historic features will be affected by this request, then they would be repaired or replaced to match the materials, design, and finishes of the original items
7. The applicant does not propose chemical or physical treatments. However, standard conditions of Structural Alteration Permit approval would require any chemical or physical treatments to be undertaken using the gentlest means possible.

8. The project does not have the potential to affect any archaeological resources because the applicant proposes no excavation.
9. The proposed upgrades are designed with complimentary, high-quality materials in simplified, contemporary style employing colors and finishes that harmonize with the historic design elements of the building. Owing to these aspects, new work will be sufficiently differentiated from the historic design.
10. If the proposed improvements were removed in the future, they would not permanently impair the integrity or essential form of the subject building.

FINDINGS REQUIRED UNDER LANDMARKS PRESERVATION ORDINANCE

1. As required by Section 3.24.260 of the Landmarks Preservation Ordinance, the Commission finds that the proposed work is appropriate for and consistent with the purposes of the Ordinance, and will preserve the characteristics and features specified in the designation for this property. Specifically:
 - A. The proposed project will not adversely affect the architectural design of the City Landmark in the Delaware Historic District, located in the 800 block of Delaware Street. It proposes the legalization of one projecting sign and two site lights installed on the South (Delaware Street) façade, and accessible upgrades to the egress door at the rear (north) of the building.
 - B. The special character of the subject property may lie in its large display windows with classic detailing and simple trim design. This project would not adversely affect these qualities because the sign and light fixtures are mounted in such a way that fits with the architectural features of the building. The rear egress door would not alter any character defining features.

STANDARD CONDITIONS

The following conditions, as well as all other applicable provisions of the Landmarks Preservation Ordinance, apply to this Permit:

1. Conditions Shall be Printed on Plans

The conditions of this Permit shall be printed on the *second* sheet of each plan set submitted for a building permit pursuant to this Permit, under the title 'Structural Alteration Permit Conditions'. *Additional sheets* may also be used if the *second* sheet is not of sufficient size to list all of the conditions. The sheet(s) containing the conditions shall be of the same size as those sheets containing the construction drawings; 8-1/2" by 11" sheets are not acceptable.

2. Plans and Representations Become Conditions

Except as specified herein, the site plan, floor plans, building elevations and/or any additional information or representations, whether oral or written, indicating the proposed structure or manner of operation submitted with an application or during the approval process are deemed conditions of approval.

3. Subject to All Applicable Laws and Regulations

The approved use and/or construction is subject to, and shall comply with, all applicable City Ordinances and laws and regulations of other governmental agencies. Prior to construction, the applicant shall identify and secure all applicable permits from the Zoning Adjustments Board or Zoning Officer, Building and Safety Division, Public Works Department and other affected City divisions and departments.

4. Exercise and Lapse of Permits

- A. A permit for the construction of a building or structure is deemed exercised when a valid City building permit, if required, is issued, and construction has lawfully commenced.
- B. A permit may be declared lapsed and of no further force and effect if it is not exercised within one year of its issuance, except that permits for construction or alteration of structures or buildings may not be declared lapsed if the permittee has: (1) applied for a building permit; or, (2) made substantial good faith efforts to obtain a building permit and begin construction, even if a building permit has not been issued and/or construction has not begun.

5. Indemnification Agreement

The applicant shall hold harmless, defend, and indemnify the City of Berkeley and its officers, agents, and employees against any and all liability, damages, claims, demands, judgments or other losses (including without limitation, attorney's fees, expert witness and consultant fees and other litigation expenses), referendum or initiative relating to, resulting from or caused by, or alleged to have resulted from, or caused by, any action or approval associated with the project. The indemnity includes without limitation, any legal or administrative challenge, referendum or initiative filed or prosecuted to overturn,

set aside, stay or otherwise rescind any or all approvals granted in connection with the Project, any environmental determination made for the project and granting any permit issued in accordance with the project. This indemnity includes, without limitation, payment of all direct and indirect costs associated with any action specified herein. Direct and indirect costs shall include, without limitation, any attorney's fees, expert witness and consultant fees, court costs, and other litigation fees. City shall have the right to select counsel to represent the City at Applicant's expense in the defense of any action specified in this condition of approval. City shall take reasonable steps to promptly notify the Applicant of any claim, demand, or legal actions that may create a claim for indemnification under these conditions of approval.

6. Halt Work/Unanticipated Discovery of Tribal Cultural Resources

In the event that cultural resources of Native American origin are identified during construction, all work within 50 feet of the discovery shall be redirected. The project applicant and project construction contractor shall notify the City Planning Department within 24 hours. The City will again contact any tribes who have requested consultation under AB 52, as well as contact a qualified archaeologist, to evaluate the resources and situation and provide recommendations. If it is determined that the resource is a tribal cultural resource and thus significant under CEQA, a mitigation plan shall be prepared and implemented in accordance with State guidelines and in consultation with Native American groups. If the resource cannot be avoided, additional measures to avoid or reduce impacts to the resource and to address tribal concerns may be required.

7. Archaeological Resources *(Ongoing throughout demolition, grading, and/or construction)*

Pursuant to CEQA Guidelines Section 15064.5(f), "provisions for historical or unique archaeological resources accidentally discovered during construction" should be instituted. Therefore:

- A. In the event that any prehistoric or historic subsurface cultural resources are discovered during ground disturbing activities, all work within 50 feet of the resources shall be halted and the project applicant and/or lead agency shall consult with a qualified archaeologist, historian or paleontologist to assess the significance of the find.
- B. If any find is determined to be significant, representatives of the project proponent and/or lead agency and the qualified professional would meet to determine the appropriate avoidance measures or other appropriate measure, with the ultimate determination to be made by the City of Berkeley. All significant cultural materials recovered shall be subject to scientific analysis, professional museum curation, and/or a report prepared by the qualified professional according to current professional standards.
- C. In considering any suggested measure proposed by the qualified professional, the project applicant shall determine whether avoidance is necessary or feasible in light of factors such as the uniqueness of the find, project design, costs, and other considerations.
- D. If avoidance is unnecessary or infeasible, other appropriate measures (e.g., data recovery) shall be instituted. Work may proceed on other parts of the project site while mitigation measures for cultural resources is carried out.

E. If significant materials are recovered, the qualified professional shall prepare a report on the findings for submittal to the Northwest Information Center.

8. Human Remains (*Ongoing throughout demolition, grading, and/or construction*)

In the event that human skeletal remains are uncovered at the project site during ground-disturbing activities, all work shall immediately halt and the Alameda County Coroner shall be contacted to evaluate the remains, and following the procedures and protocols pursuant to CEQA Guidelines Section 15064.5 (e)(1) . If the County Coroner determines that the remains are Native American, the City shall contact the California Native American Heritage Commission (NAHC), pursuant to Health and Safety Code Section 7050.5(c), and all excavation and site preparation activities shall cease within a 50-foot radius of the find until appropriate arrangements are made. If the agencies determine that avoidance is not feasible, then an alternative plan shall be prepared with specific steps and timeframe required to resume construction activities. Monitoring, data recovery, determination of significance and avoidance measures (if applicable) shall be completed expeditiously.

9. Paleontological Resources (*Ongoing throughout demolition, grading, and/or construction*)

In the event of an unanticipated discovery of a paleontological resource during construction, excavations within 50 feet of the find shall be temporarily halted or diverted until the discovery is examined by a qualified paleontologist (per Society of Vertebrate Paleontology standards [SVP 1995,1996]). The qualified paleontologist shall document the discovery as needed, evaluate the potential resource, and assess the significance of the find. The paleontologist shall notify the appropriate agencies to determine procedures that would be followed before construction is allowed to resume at the location of the find. If the City determines that avoidance is not feasible, the paleontologist shall prepare an excavation plan for mitigating the effect of the project on the qualities that make the resource important, and such plan shall be implemented. The plan shall be submitted to the City for review and approval.

ADDITIONAL CONDITIONS

The following additional conditions are attached to this Permit:

10. No changes can be made to these approved plans without prior approval.
11. **CITY PERMITS.** This Structural Alteration Permit (SAP) approval is contingent upon approval of the requisite Use Permit and Public Work Permit for the project scope.
12. **PLANS COMPLIANCE.** Construction and building permit plans shall substantially conform to the Structural Alteration Permit (SAP) project plans dated/received February 28, 2023.
13. **REPAIR AND REPLACEMENT OF CHARACTER-DEFINING FEATURES.** Deteriorated historic features shall be repaired rather than replaced. Where the severity of deterioration requires replacement of a distinctive feature, the new feature shall match the old or historic feature in design, color, texture, and, where possible,

materials. Replacement of missing features shall be substantiated by documentary and physical evidence.

14. Chemical or physical treatments, if appropriate, shall be undertaken using the gentlest means possible. Treatments that cause damage to historic materials shall not be used.
15. **COLORS.** Prior to Landmarks plan checker sign-off of the Building Permit set of drawings, the applicant shall submit color and materials information for review and approval by Landmarks staff, in coordination with the LPC Chair as needed.
16. **CLEAR GLASS.** All glass is assumed to be clear glass. Any proposed glass that is not clear glass, or includes signage, shall be indicated on all drawings, and shall be reviewed for approval by Landmarks staff.
17. **DETAILS.** Prior to Landmarks plan checker sign-off of the Building Permit set of drawings, the applicant shall submit sign, light fixture, double door, and transom details for review and approval by the Landmarks plan checker.
18. **SIGNAGE.** Prior to Landmarks plan checker sign-off of the building permit set of drawings, the applicant shall submit complete signage details, including colors, materials, letter heights, dimensions, placement on building, and installation details. All materials will be matte unless otherwise noted. All non-temporary signage and awnings not previously approved and not listed in this application are prohibited.
19. **LIGHTING.** Prior to Landmarks plan checker sign-off of the building permit set of drawings, the applicant shall submit lighting details showing all existing and proposed site and building lighting. Exterior lighting, including for signage, shall be downcast and not cause glare on the public right-of-way and adjacent parcels.

Existing light fixtures shall either be replaced or refinished with a matte or flat finish.

20. The applicant shall be responsible for identifying and securing all applicable permits from the Building and Safety Division and all other affected City divisions/departments prior to the start of work.
21. The applicant is responsible for complying with all the above conditions. Failure to comply with any condition could result in construction work being stopped, issuance of citations, as well as further review by the Landmarks staff, which may modify or impose additional conditions, or revoke approval.
22. All building permit drawings and subsequent construction shall substantially conform to the approved plans as outlined in Condition #1. Any modifications must be reviewed by the Landmarks plan checker to determine whether the modification requires approval.
23. The applicant shall hold harmless, defend, and indemnify the City of Berkeley and its officers, agents, and employees against any and all liability, damages, claims, demands, judgments or other losses (including without limitation, attorney's fees, expert witness and consultant fees and other litigation expenses), referendum or initiative relating to, resulting from or caused by, or alleged to have resulted from, or caused by, any action or approval associated with the project. The indemnity includes without limitation, any

legal or administrative challenge, referendum or initiative filed or prosecuted to overturn, set aside, stay or otherwise rescind any or all approvals granted in connection with the Project, any environmental determination made for the project and granting any permit issued in accordance with the project. This indemnity includes, without limitation, payment of all direct and indirect costs associated with any action specified herein. Direct and indirect costs shall include, without limitation, any attorney's fees, expert witness and consultant fees, court costs, and other litigation fees. City shall have the right to select counsel to represent the City at Applicant's expense in the defense of any action specified in this condition of approval. City shall take reasonable steps to promptly notify the Applicant of any claim, demand, or legal actions that may create a claim for indemnification under these conditions of approval.



RETAIL TENANT IMPROVEMENT

803 DELAWARE ST., BERKELEY, CA 94710

DESCRIPTION OF WORK

TENANT IMPROVEMENT WITH MINOR STRUCTURAL ADJUSTMENT TO RETAIL SPACE.

PROJECT INFORMATION

PARCEL:	57-2098-46
ZONING:	MUR
LOT SIZE:	RETAIL CONDO UNIT WITHIN LOT
SPRINKLERS:	NONE - NO CHANGE
CONSTRUCTION TYPE:	VB (NO CHANGE)
OCCUPANCY:	M = RETAIL CONDO (NO CHANGE)
(E) HEIGHT:	+27'-0"
PROPOSED HEIGHT:	NO CHANGE
(E) STORIES:	2 STORIES
PROPOSED STORIES:	2 STORIES (NO CHANGE)
(E) PARKING:	SHARED LOT IN CONDO
(N) PARKING PROVIDED:	NONE - NO CHANGE
BUILDING FOOTPRINT:	869 SF
TOTAL AREA OF BUILDING:	1,754 SF
AREA OF WORK:	780 SF (INTERIOR TENANT IMPROVEMENT)

SHEET INDEX

ARCHITECTURAL		BUILDING
SHEET NUMBER	SHEET NAME	
A0.0	TITLE SHEET	•
A0.1	GENERAL NOTES & ABBREVIATIONS	•
A0.2	TITLE-24	•
A0.3	TITLE-24	•
A0.4	TITLE-24	•
A0.5	TITLE-24	•
A0.6	TITLE-24	•
A0.7	TITLE-24	•
A1.0	EXISTING SITE PLAN	•
A2.0	EXISTING FIRST FLOOR & DEMO PLAN	•
A2.1	IMPROVEMENT FLOOR PLAN	•
A2.1	IMPROVEMENT BUILDING PLAN - FIRST FLOOR	•
A2.2	IMPROVEMENT RCP	•
A3.0	EXISTING AND IMPROVEMENT ELEVATIONS	•
A4.0	DETAILS	•
A4.1	ACCESSIBILITY DETAILS	•
S1	STRUCTURAL NOTES	•
S2	FOUNDATION SHEAR WALLS & FOUNDATION DETAILS	•
S3	STEEL MOMENT FRAMING DETAILS	•



GUNKEL ARCHITECTURE
1295 59TH STREET
EMERYVILLE CA 94608
GUNKELARCHITECTURE.COM
PHONE: (510) 984 - 1112



RETAIL RENOVATION
803 DELAWARE STREET
BERKELEY, CA 94710

TITLE SHEET

BUILDING PERMIT

DATE 10/06/22

A0.0

CODE COMPLIANCE

- 2019 CALIFORNIA BUILDING CODE (INCORPORATES BY ADOPTION AND REPRINTS THE 2018 INTERNATIONAL BUILDING CODE WITH CALIFORNIA AMENDMENTS. PUBLISHED BY THE INTERNATIONAL CODE COUNCIL, ICC)
- 2019 CALIFORNIA RESIDENTIAL CODE - APPLIES TO ONE AND TWO FAMILY HOUSES AND TOWNHOMES LESS THAN 3 STORIES IN HEIGHT. (INCORPORATES BY ADOPTION AND REPRINTS THE 2018 INTERNATIONAL RESIDENTIAL CODE.)
- 2019 CALIFORNIA ENERGY CODE - CHECK THE CALIFORNIA ENERGY COMMISSION'S WEBSITE AT [HTTP://WWW.ENERGY.CA.GOV](http://WWW.ENERGY.CA.GOV) FOR A DOWNLOADABLE VERSION. (PUBLISHED BY ICC).
- 2019 CALIFORNIA ELECTRICAL CODE (INCORPORATES BY ADOPTION AND REPRINTS THE 2017 NATIONAL ELECTRICAL CODE WITH CALIFORNIA AMENDMENTS. PUBLISHED BY THE NATIONAL FIRE PROTECTION AGENCY, NFPA)
- 2019 CALIFORNIA PLUMBING CODE (INCORPORATES BY ADOPTION AND REPRINTS THE 2018 UNIFORM PLUMBING CODE WITH CALIFORNIA AMENDMENTS. PUBLISHED BY THE INTERNATIONAL ASSOCIATION OF PLUMBING AND MECHANICAL OFFICIALS, IAPMO)
- 2019 CALIFORNIA MECHANICAL CODE (INCORPORATES BY ADOPTION AND REPRINTS THE 2018 UNIFORM MECHANICAL CODE WITH CALIFORNIA AMENDMENTS. PUBLISHED BY THE INTERNATIONAL ASSOCIATION OF PLUMBING AND MECHANICAL OFFICIALS, IAPMO)
- 2019 CALIFORNIA FIRE CODE (INCORPORATES BY ADOPTION AND REPRINTS THE 2018 INTERNATIONAL FIRE CODE WITH CALIFORNIA AMENDMENTS. PUBLISHED BY ICC)
- 2019 CALGREEN CODE - APPLIES TO CERTAIN NEW BUILDINGS ONLY - ALL NEW RESIDENTIAL BUILDINGS 3 STORIES OR LESS AND ALL NEW NON-RESIDENTIAL BUILDINGS. HERS VERIFICATION REQUIRED BY T-24 ENERGY REPORT.

VICINITY MAP

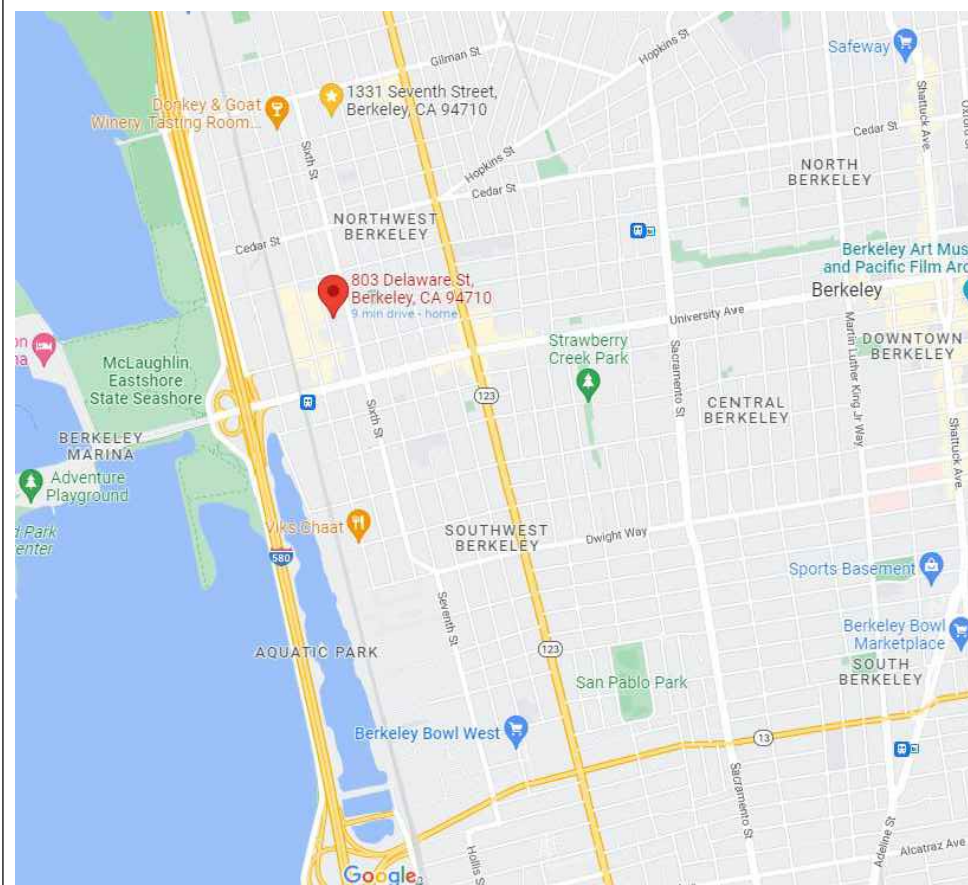

ASSESSOR'S MAP

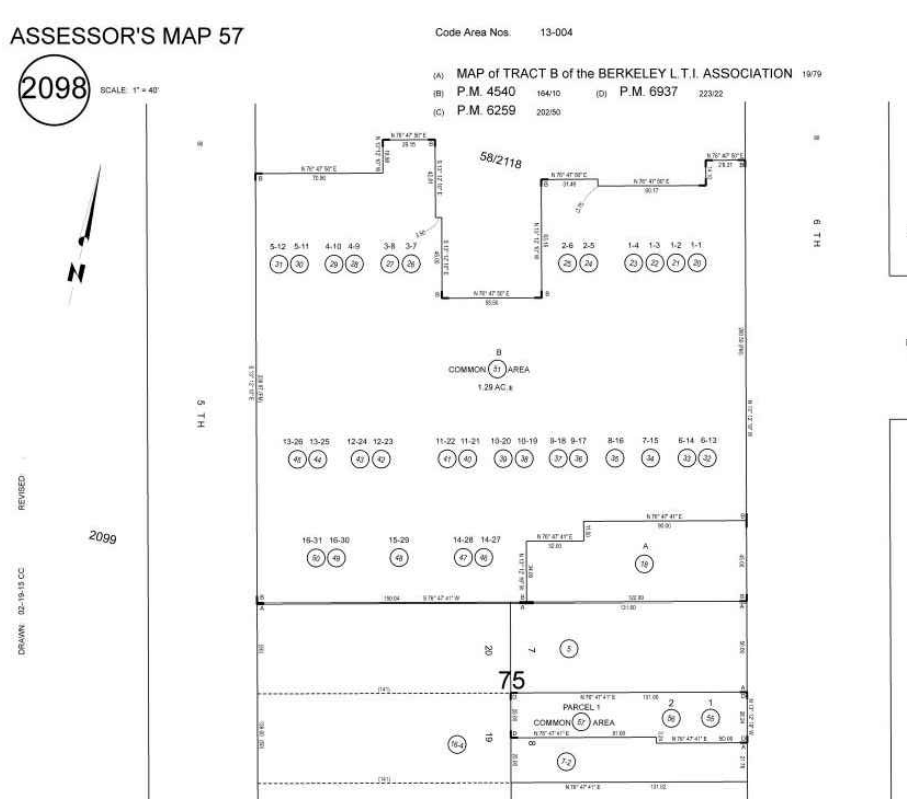

PROJECT TEAM

OWNER
SHARON BLOCK & SALIM AYKIRAN
TURKISH TOWEL COMPANY
803 DELAWARE STREET
BERKELEY, CA 94710
TTC@TURKISHTOWELCOLLECTION.COM

ARCHITECT
GUNKEL ARCHITECTURE
2295 SAN PABLO AVENUE
BERKELEY, CA, 94702
(510) 984-1112
PROJECT MANAGER: AMBER BAKER
AMBER@GUNKELARCHITECTURE.COM

STRUCTURAL
JEDCO CONSULTING ENGINEERS
1000 CONTRA COSTA DRIVE
EL CERRITO, CA 94530
(510) 703-0095
ENGINEER: FIRAS A. JANDALI
FIRASJANDALI@YAHOO.COM

FIRE SAFETY DURING CONSTRUCTION

- DURING CONSTRUCTION SITE OR AREA MUST BE CLEANED UP AT THE END OF THE DAY IN ORDER TO PROVIDE FIREFIGHTER ACCESS IN THE BUILDING IN AN EVENT OF A FIRE.
- COMBUSTIBLE DEBRIS SHALL NOT BE ACCUMULATED WITHIN THE BUILDING. COMBUSTIBLE DEBRIS, RUBBISH AND WASTE MATERIAL SHALL BE REMOVED FROM BUILDINGS AT THE END OF EACH WORK SHIFT [CFC §330.4.2.4]
- MATERIALS SUSCEPTIBLE TO SPONTANEOUS IGNITION, SUCH AS OILY RAGS, SHALL BE STORED IN A LISTED DISPOSAL CONTAINER [CFC §330.4.2.4]
- OPERATIONS INVOLVING THE USE OF CUTTING AND WELDING SHALL BE DONE IN ACCORDANCE WITH CFC §3304.6.

SYMBOLS

HEIGHT		DETAIL		WALL TAG	
SECTION		GRIDLINE			
EXTERIOR ELEVATION		DEMOLITION NOTE			
		IMPROVEMENT NOTE			

DRAWING NOTES

TYPICAL OWNER/DEVELOPER BUILDING PERMIT SET OF DRAWINGS:
THESE DRAWINGS ARE INTENDED FOR BUILDING PERMIT APPROVAL AND ARE NOT INTENDED TO BE A COMPREHENSIVE SET OF DRAWINGS INDICATING CONSTRUCTION DETAILS, WATER PROOFING, SPECIFIC FINISHES, SPECIFIC CABINETS, SPECIFIC PLUMBING FIXTURES, LIGHTING FIXTURES, SPECIFIC DOORS, WINDOWS & HARDWARE OR M.E.P. & UTILITY ROUTING. OWNER/DEVELOPER IS RESPONSIBLE FOR THE SELECTION OF THESE ITEMS AND CLARIFICATION AND COORDINATION OF THESE WITH THE CONTRACTOR AS PART OF THE BUILDING CONTRACT AND CONSTRUCTION PROCESS. CONTRACTOR IS RESPONSIBLE FOR CONFIRMING CODE COMPLIANCE OF ALL WORK NOT FULLY REFLECTED IN THESE DOCUMENTS AS WELL AS ANY REVISIONS TO THIS SCOPE WITH THE ENTITIES HAVING JURISDICTION. CONTRACTOR IS RESPONSIBLE FOR PROVIDING A COMPLETE, STRUCTURALLY SOUND, FULLY OPERATIONAL CODE COMPLIANT, FINISHED WORK WITH COMPLETE PROTECTION AGAINST ELEMENTS.

ENERGY CALCULATIONS

BRIGHT GREEN STRATEGIES
820 DELAWARE STREET
BERKELEY, CA 94710
SHARON BLOCK
(510) 863-1109
INFO@BRIGHTGREENSTRATEGIES.COM

ABBREVIATIONS

AB.	ANCHOR BOLT	F.V.	FIELD VERIFY	N.T.S.	NOT TO SCALE	SYM.	SYMMETRICAL
ABV.	ABOVE	F.F.	FINISH FLOOR	N.W.	NORTHWEST		
A.C.	ASPHALTIC CONCRETE	F.H.C.	FIRE HOSE CABINET			T.	TREAD
A.C.T.	ACOUSTICAL CEILING TILE	FIN.	FINISH	OBS.	OBSURE	T.B.	TACKBOARD
AC	AIR CONDITIONING	FIX.	FIXTURE	O.C.	ON CENTER	TECH.	TECHNOLOGY
ACOUS.	ACOUSTICAL	F.L.	FLOW LINE	O.D.	OUTSIDE DIAMETER or DIMENSION	TELE.	TELEPHONE
AD.	AREA DRAIN	FLR.	FLOOR	O.F.C.I.	OWNER FURNISHED, CONTRACTOR INSTALLED	TEMP.	TEMPERED or TEMPERATURE
ADMIN.	ADMINISTRATION	FLUOR.	FLUORESCENT	O.F.S.	OVERFLOW DRAIN	THK.	THICK
ADJ.	ADJUSTABLE	F.O.	FACE OF	O.F.S.	OVERFLOW SCUPPER	T & G	TONGUE & GROOVE
A.F.F.	ABOVE FINISHED FLOOR	F.O.C.	FACE OF CONCRETE	O.F.S.	OVERFLOW SCUPPER	THRES.	THRESHOLD
AGGR.	AGGREGATE	F.O.F.	FACE OF FINISH	O.H.	OVER HEAD	T.O.	TOP OF
AL.	ALUMINUM	F.O.M.	FACE OF MASONRY	O.P.N.G.	OPENING	T.O.C.	TOP OF CURB or CONCRETE
ALT.	ALTERNATE	F.O.S.	FACE OF STUD	OPP. HD.	OPPOSITE HAND	T.O.D.	TOP OF DECKING
APP.	ACCESS PANEL	F.O.W.	FACE OF WALL	OZ.	OUNCE	T.O.M.	TOP OF MASONRY
APPROX.	APPROXIMATE	FRM'G	FRAMING			T.O.P.	TOP OF PAVEMENT or PARAPET
ARCH.	ARCHITECTURAL	F.R.T.	FIRE RETARDANT TREATED	P.A.	PLANTING AREA	T.O.S.	TOP OF STEEL
ASPH.	ASPHALT	F.R.P.	FIBERGLASS REINFORCED	P.B.	PANIC BAR	T.O.W.	TOP OF WALL
ATTEN.	ATTENUATING	P.C.P.	PRECAST CONCRETE PANEL	PERIM.	PERIMETER	T.S.	TUBULAR STEEL
		F.S.	FLOOR SINK	PL.	PLATE	T.S.C.D.	TOILET SEAT COVER
BD.	BOARD	F.S.E.	FLOOR SERVICE EQUIPMENT	PL.G.	PLATE GLASS		DISPENSER
BET.	BETWEEN	FT.	FOOT OR FEET	PL.G.	PLATE GLASS	T.T.D.	TOILET TISSUE DISPENSER
B.F.	BRACED FRAME	FTG.	FOOTING	PLAM.	PLASTIC LAMINATE	TV	TELEVISION
BLDG.	BUILDING	FURR.	FURRING	PLAS.	PLASTER	TYP.	TYPICAL
BLK.	BLOCKING	FUT.	FUTURE	PLBG.	PLUMBING	U.B.C.	UNIFORM BUILDING CODE
BM.	BEAM			PLYWD.	PLYWOOD	U.G.	UNDERGROUND
BOT.	BOTTOM	GA.	GAUGE	PNL.	PANEL	U.L.	UNDERWRITERS LABORATORY UNFINISHED UR.
		GA.LV.	GALVANIZED	PK.	PAIR		
CAB.	CABINET	GL.B.	GLUE- LAMINATED (WOOD)	PREP.	PREPARATION		
C.C.	CENTER TO CENTER			P.S.F.	POUNDS PER SQUARE FOOT		
CEM.	CEMENT	GL.	GLASS	P.S.I.	POUNDS PER SQUARE INCH	UNF.	UNFINISHED
CER.	CERAMIC	GND.	GROUND	P.T.	PRESSURE TREATED	U.O.N.	UNLESS OTHERWISE NOTED
C.F.	CUBIC FEET	G.R.G.	GLASS REINFORCED	PT.	POINT	UR.	URINAL
CH.	CHANNEL	P.T.D.	PAPER TOWEL DISPENSER				
C.I.	CAST IRON	G.S.M.	GALVANIZED SHEET METAL	PTN.	PARTITION	V.C.T.	VINYL COMPOSITION TILE
CL.	CONTROL JOINT	PVC	POLYVINYL CHLORIDE	PVC	VERTICAL	VERT.	VERTICAL
C.L.	CENTERLINE	G.W.B.	GYPNUM WALL BOARD	PVMT.	PAVEMENT	VEST.	VESTIBULE
CLG.	CEILING			V.G.D.F.	VERTICAL GRAIN DOUGLAS FIR		
CLKG.	CAULKING	H.B.	HOSE BIBB	R.	RISER OR REFRIGERATOR REMOVE	V.I.F.	VERIFY IN FIELD
CLO.	CLOSET	H.C.	HOLLOW CORE	(R)	REMOVE	VOL.	VOLUME
CLR.	CLEAR	HDWR.	HARDWARE	R.A.	RETURN AIR	V.T.R.	VENT THRU ROOF (S.P.D.)
C.M.U.	CONCRETE MASONRY UNIT	HDWD.	HARDWOOD	RAD.	RADIUS	V.W.C.	VINYL WALL COVERING
COL.	COLUMN	HT.	HEIGHT	R.B.	RUBBER BASE		
COMP.	COMPUTER	H.M.	HOLLOW METAL	R.C.P.	REFLECTED CEILING PLAN		
CONC.	CONCRETE	HORIZ.	HORIZONTAL	R.D.	ROOF DRAIN	W.	WEST OR WASHER
CONF.	CONFERENCE	H.P.	HIGH POINT	REF.	REFERENCE	W/	WITH
CONT.	CONTINUOUS	HVAC	HEATING, VENTILATING, AIR CONDITIONING	REF.	REFRIGERATOR	W.C.	WATER CLOSET
CONTR.	CONTRACTOR			REF.	REFRIGERATION	WD	WOOD
CONST.	CONSTRUCTION			REIN.	REINFORCED	WD.	WOOD
CORR.	CORRIDOR	I.D.	INSIDE DIAMETER	REQD.	REQUIRED	WDW.	WINDOW
CPT.	CARPET	IN.	INCH	REV.	REVISION OR REVISED	W.F.	WIDE FLANGE
C.R.	COLD-ROLLED	INCAND.	INCANDESCENT	RESIL.	RESILIENT	WGL.	WIRE GLASS
CSMT.	CASEMENT	INCR.	INCREMENT	R.H.	RIGHT HAND	WH.	WATER HEATER
C.T.	CERAMIC TILE	INFO.	INFORMATION	RM.	ROOM	W.I.C.	WOODWORK INSTITUTE OF CALIFORNIA
CTR.	CENTER	INSUL.	INSULATION	R.O.	ROUGH OPENING		
CTS.K.	COUNTERSUNK	INT.	INTERIOR	RWD.	REDWOOD	W.O.	WHERE OCCURS
C.Y.	CUBIC YARDS			R.W.L.	RAINWATER LEADER	W/O	WITHOUT
		JAN.	JANITOR	S.	SOUTH	W.P.	WORKING POINT
D.	DRYER	JST.	JOIST	S.A.	SUPPLY AIR	W.SCT.	WAINSCOT
DBL.	DOUBLE	JT.	JOINT	S.B.	SCOREBOARD	W.S.P.	WET STANDPIPE
DECK.	DECKING	KIT.	KITCHEN	S.C.	SOLID CORE	WT.	WEIGHT
DEG.	DEGREE	K.P.	KICK PL	S.C.D.	SEE CIVIL DRAWINGS	W.W.F.	WELDED WIRE FABRIC
DEMO.	DEMOLITION			SCHED.	SCHEDULE		
DEPT.	DEPARTMENT	LAB.	LABORATORY	S.D.	SECTOR DRAIN	&	AND
DET.	DETAIL	LAM.	LAMINATE	S.D.S.	SEE DOOR SCHEDULE	@	AT
D.F.	DRINKING FOUNTAIN	LAV.	LAVATORY	S.E.	SOUTHEAST	CH	CHANNEL
DIA.	DIAMETER	L.B.	POUND	S.E.D.	SEE ELECTRICAL DRAWINGS	d	PENNY
DIM.	DIMENSION	L.F.	LINEAR FEET	SECT.	SECTION	#	POUND OR NUMBER
DIR.	DIRECTION	L.H.	LEFT HAND	S.F.	SQUARE FOOT (FEET)		
DISP.	DISPOSAL	LN.	LINEAR	S.F.S.	SEE (ROOM) FINISH		
DIST.	DISTRIBUTION	LKR.	LOCKER	SCHEDULE			
DIV.	DIVISION	L.L.H.	LONG LEG HORIZONTAL	S.G.S.	SEE GLAZING SCHEDULE		
DN.	DOWN	L.P.	LOW POINT	SHT.	SHEET		
DR.	DOOR	L.T.	LIGHT	SHTG.	SHEATHING		
D.S.	DOWNSPOUT	LVR.	LOUVER	SIM.	SIMILAR		
D.S.A.	DIVISION OF STATE ARCHITECT	MACH.	MACHINE	S.L.D.	SEE LANDSCAPE DRAWINGS		
D.S.P.	DRY STAND PIPE	MACH.	MACHINE	S.M.	SHEET METAL		
DWG.	DRAWING	MATL.	MAINTENANCE MATERIAL	SL	SLOPE		
		MAS.	MASONRY	SMACNA	SHEET METAL AND AIR CONDITIONING		
E.	EAST	MAX.	MAXIMUM				
(E)	EXISTING	M.B.	MARKER BOARD or MACHINE BOLT	S.M.D.	SEE MECHANICAL DRAWINGS		
EA.	EACH	M.C.	MEDICINE CABINET	S.M.S.	SHEET METAL SCREW		
EJ.	EXPANSION JOINT	M.E.C.	MECHANICAL ELECTRICAL & PLUMBING	S.N.R.	SANITARY NAPKIN DISPENSER		
EL.	ELEVATION	MET.	METAL	S.O.G.	SLAB ON GRADE		
ELAS.	ELASTOMERIC	MFR.	MANUFACTURER	S.P.D.	SEE PLUMBING DRAWINGS		
ELEC.	ELECTRICAL	MIC/TC	MICROWAVE TOASTER	SPEC.	SPECIFICATION		
ELEV.	ELEVATOR	MIN.	MINIMUM	SPR	SPRINKLERED		
EMER.	EMERGENCY	MIR.	MIRROR	S.P.S.	SEE PARTITION SCHEDULE		
ENCL.	ENCLOSURE	MISC.	MISCELLANEOUS	SQ.	SQUARE		
ENGR.	ENGINEER	MK.	MARK	S.S.D.	SEE STRUCTURAL DRAWINGS		
EQ.	EQUAL	M.O.	MASONRY OPENING	STD.	STANDARD		
EQUIP.	EQUIPMENT	MTD.	MOUNTED	STL.	STEEL		
E.S.	EACH SIDE	MUL.	MULLION	STRL.	STRUCTURAL		
EXP.	EXPANSION			S4S	SURFACE FOUR SIDES		
EXH.	EXHAUST	N.	NORTH	S2S	SURFACE TWO SIDES		
EXIST.	EXISTING	(N)	NEW	S.S.	STAINLESS STEEL		
EXT.	EXTERIOR	N/A	NOT APPLICABLE	SVC	SERVICE		
E.W.	EACH WAY	N.E.	NORTHEAST	STOR	STORAGE		
		N.I.C.	NOT IN CONTRACT	SUSP.	SUSPENDED		
F.	FREEZER	NO.	NUMBER	S.W.	SOUTHWEST		
F.A.	FIRE ALARM	NOM.	NOMINAL	S.W.S.	SEE WINDOW SCHEDULE		
F.A.F.	FORCED AIR FURNACE						
F.D.	FLOOR DRAIN						
F.N.D.	FOUNDATION						
F.E.	FIRE EXTINGUISHER						
F.E.C.	FIRE EXTINGUISHER & CABINET						
FED.	FEDERAL						

GENERAL NOTES

- CONTRACTOR SHALL VISIT THE SITE PRIOR TO SUBMISSION OF BIDS TO REVIEW EXISTING CONDITIONS OF AREAS THAT ARE TO BE BID.
- ADMINISTRATIVE REQUIREMENTS:
2A. THE INTENT OF THESE DRAWINGS AND SPECIFICATIONS IS THAT THE WORK OF THE ALTERATION AND ADDITIONS IS TO BE IN ACCORDANCE WITH TITLE 24, CALIFORNIA CODE OF REGULATIONS. SHOULD ANY EXISTING CONDITIONS SUCH AS DETERIORATION OR NON-COMPLYING CONSTRUCTION BE DISCOVERED WHICH IS NOT COVERED BY THE CONTRACT DOCUMENTS WHEREIN THE FINISHED WORK WILL NOT COMPLY WITH TITLE 24, CALIFORNIA CODE OF REGULATIONS, A CHANGE ORDER OR A SEPARATE SET OF DRAWINGS AND SPECIFICATIONS, DETAILING AND SPECIFYING THE REQUIRED WORK SHALL BE SUBMITTED TO AND APPROVED BY AREA HAVING JURISDICTION BEFORE PROCEEDING WITH THE WORK.
- USE OF ANY MATERIAL CONTAINING ASBESTOS IS PROHIBITED.
- DO NOT SCALE DRAWINGS. DRAWINGS SHOULD BE USED AS A SUPPLEMENTAL TOOL FOR THE CONTRACTOR'S USE IN REVIEWING ACTUAL FIELD CONDITIONS PRIOR TO BIDDING.
- DIMENSIONS FROM EXISTING SURFACE OR ASSEMBLIES ARE APPROXIMATE DUE TO THE AS-BUILT CONDITIONS VARYING FROM ACTUAL FIELD CONDITIONS. ALL DIMENSIONS ARE TO BE FIELD VERIFIED PRIOR TO COMMENCING WORK. DIMENSIONS ARE FROM TO CENTERLINE OR FACE OF STUDS/HEATHING U.O.N. PER PLANS.
- MATCH LINES ARE INDICATORS OF WHERE ADJOINING FLOOR PLANS MEET. SEE PLANS ON BOTH SIDES OF MATCH LINE FOR INFORMATION OVERLAPPING THE LINE.
- THE INTENT OF THESE DRAWINGS AND SPECIFICATIONS IS TO INCLUDE ALL LABOR, MATERIALS, EQUIPMENT, AND SERVICES NECESSARY FOR ALL WORK SHOWN, PRESCRIBED, OR REASONABLY IMPLIED, BUT NOT LIMITED TO THAT EXPLICITLY INDICATED IN THE CONTRACT DOCUMENTS. WHERE WORK OR EQUIPMENT IS INDICATED N.I.C. (NOT IN CONTRACT), SUCH WORK AND/OR EQUIPMENT SHALL BE PROVIDED BY OTHERS. CONTRACTOR SHALL COORDINATE AND COOPERATE TO EFFECT SUCH INSTALLATION. ALL REQUESTS FOR CLARIFICATIONS OF THESE DRAWINGS SHALL BE DIRECTED TO THE ARCHITECT OF RECORD. ALL REQUIRED WORK SHALL BE PERFORMED BY THE CONTRACTOR INCLUDING THE GENERAL CONTRACTOR AND HIS SUBCONTRACTORS. THEY SHALL BE ONE AND THE SAME. THE CONTRACTOR SHALL COORDINATE HIS WORK WITH ALL OTHER TRADES ON THE PROJECTS. ANY CHANGES OR DELAYS ARISING FROM CONFLICTS BETWEEN TRADES SHALL BE THE RESPONSIBILITY OF THE CONTRACTOR AT NO ADDITIONAL COST TO THE OWNER. THE CONTRACTOR SHALL BE RESPONSIBLE FOR ASSURING THAT ALL TRADES COORDINATE INTERFACE BETWEEN THEMSELVES, IE. PLUMBING, ROUGH-IN CABINETS, ETC.
- EXISTING UTILITIES AND IMPROVEMENTS DAMAGED DURING THE COURSE OF THE WORK SHALL BE PROMPTLY REPAIRED. EXISTING UTILITIES AND IMPROVEMENTS DAMAGED FOR WHICH LOCATIONS WERE UNKNOWN, SHALL BE IMMEDIATELY BROUGHT TO THE OWNERS AND ARCHITECT'S ATTENTION AND PROMPTLY REPAIRED AT HIS/HER DIRECTION. THE WORK REQUIRED TO REPAIR DAMAGED EXISTING UTILITIES AND IMPROVEMENTS FOR WHICH LOCATIONS WERE UNKNOWN WILL BE REVIEWED AND TAKEN UNDER CONSIDERATION AS EXTRA WORK.
- ALL ITEMS NOTED TO BE SALVAGED SHALL BE RETURNED TO THE OWNER.
- THE TERM "TYPICAL" (TYP) SHALL BE CONSTRUED TO MEAN APPLYING TO ALL LIKE OR SIMILAR CONDITIONS IN THE AREAS DESIGNATED FOR WORK SCOPE (IE. WITHIN THE BOUNDARIES OF THIS PROJECT).
- PENETRATIONS IN FIRE RATED ASSEMBLIES AND BEARING WALLS SHALL BE PROTECTED AS REQUIRED BY 2019 CBC CHAPTER 7.
- THE CONSTRUCTION DOCUMENTS, INCLUDING THE SPECIFICATIONS, PLANS AND DRAWINGS, ARE COMPLEMENTARY AND WHAT IS CALLED FOR BY ANY ONE SHALL BE AS BINDING AS IF CALLED FOR BY ALL. IN CASE OF CONFLICT, LARGE SCALE (DETAIL) DRAWINGS SHALL GOVERN OVER SMALL-SCALE DRAWINGS. THE SPECIFICATIONS SHALL GOVERN OVER BOTH THE CONSTRUCTION PROCEDURES MANUAL AND THE CONTRACT DRAWINGS EXCEPT AS NOTED HEREIN BELOW. SPECIAL PROVISIONS SHALL GOVERN OVER BOTH THE CONSTRUCTION DRAWINGS AND THE GENERAL CONDITIONS, AND SUBSEQUENT ADDENDA. INTERPRETATIONS, OR CHANGE ORDERS SHALL GOVERN OVER THE ORIGINAL DOCUMENTS, UNLESS A DIFFERENT ORDER OF PROCEDURE IS NOTED ELSEWHERE IN CONJUNCTION WITH A SPECIFIC PORTION OF THE DOCUMENTS.

IN CASE OF CONFLICT BETWEEN THE DRAWINGS AND SPECIFICATIONS, THE DOCUMENT CONTAINING ADDITIONAL QUANTITIES SHALL GOVERN IN MATTERS OF QUANTITY; THE DOCUMENT REQUIRING A HIGHER DEGREE OF QUALITY SHALL GOVERN IN MATTERS OF QUALITY. IN CASE OF CONFLICT WITHIN THE DRAWINGS INVOLVING QUANTITIES OR WITHIN THE SPECIFICATIONS INVOLVING QUALITY, THE GREATER QUANTITY AND THE HIGHER QUALITY SHALL BE FURNISHED. THE CONTRACTOR SHALL NOTIFY THE ARCHITECT OF ALL SUCH QUANTITY AND QUALITY CONFLICTS AND SHALL AGREE UPON RESOLUTION, IN WRITING, PRIOR TO PROCEEDING.

WHERE ON ANY DRAWING A PORTION OF THE WORK IS DRAWN OUT AND THE REMAINDER IS INDICATED IN OUTLINE, THE DRAWN-OUT PARTS SHALL APPLY TO ALL OTHER LIKE PORTIONS OF THE WORK. WHERE ORNAMENT OR OTHER DETAILS IS INDICATED AS STARTING, SUCH DETAIL SHALL BE CONTINUED THROUGHOUT THE COURSES OR PARTS IN WHICH IT OCCURS AND SHALL ALSO APPLY TO OTHER SIMILAR PARTS IN THE WORK, UNLESS OTHERWISE INDICATED.
- ITEMS INDICATED TO BE VERIFIED OR FIELD VERIFIED ARE REQUIRED TO BE VERIFIED PRIOR TO ORDERING MATERIALS OR PROCEEDING WITH THE WORK. ITEMS ARE ALWAYS TO BE VERIFIED FOR DESIGN INTENT AND COMPATIBILITY
- THE CONTRACTOR SHALL MAINTAIN THE PUBLIC RIGHTS OF WAY, SIDEWALKS, CORRIDORS, ETC., AFFECTED BY THE CONSTRUCTION, AND KEEP THESE AREAS FREE OF ALL SOIL, DEBRIS, TRASH, ETC., ON A DAILY BASIS. CLEAN EGRESS SHALL BE MAINTAINED AT ALL TIMES FOR ALL ADJACENT BUILDING TENANTS, THEIR EMPLOYEES AND GUESTS.
- THE ARCHITECT'S APPROVAL OF SHOP DRAWINGS SHALL NOT RELIEVE THE GENERAL CONTRACTOR FROM RESPONSIBILITY FOR DEVIATIONS FROM DRAWINGS OR SPECIFICATIONS UNLESS HE HAS (IN WRITING) CALLED THE ARCHITECT'S ATTENTION TO SUCH DEVIATIONS AT THE TIME OF SUBMISSION NOR SHALL IT RELIEVE HIM OF RESPONSIBILITY FOR ERRORS OF ANY SORT IN THE SHOP DRAWINGS.
- GENERAL CONTRACTOR OR ITS SUBCONTRACTORS SHALL BE RESPONSIBLE FOR VERIFICATION AND APPROVALS OF SUBSTITUTED MATERIALS AS REQUIRED BY GOVERNING CODES AND AGENCIES.
- IT SHALL BE THE RESPONSIBILITY OF THE GENERAL CONTRACTORS TO SUPPLY AND DISTRIBUTE ADEQUATE COPIES OF ALL DRAWINGS TO ALL TRADES FALLING UNDER THEIR RESPONSIBILITY AT ALL TIMES DURING THE PROGRESS OF THE JOB (IE. REVISIONS).
- UPON COMPLETION OF THE JOB, THE GENERAL CONTRACTOR SHALL SUBMIT CERTIFICATES OF INSPECTION OF SATISFACTORY COMPLETION, AND OPERATION AND MAINTENANCE INSTRUCTIONS OF ALL EQUIPMENT TO THE OWNER AND TENANT. CONTRACTOR SHALL BE RESPONSIBLE FOR PROVIDING ALL WORK AND MATERIALS IN CONFORMANCE WITH ANY CODE OR CODES OF FEDERAL, STATE, COUNTY OR MUNICIPALITY HAVING JURISDICTION OVER SUCH WORK. ALL APPLICABLE REQUIREMENTS IN THESE REGULATIONS ALL BE FOLLOWED THE SAME AS IF NOTED ON THE DRAWINGS. CONFLICTS BETWEEN WORK SET FORT ON THE DRAWINGS AND BUILDING CODES, LAWS OR REGULATIONS NOTED BY THE GENERAL CONTRACTOR SHALL BE SUBMITTED TO THE ARCHITECT FOR RESOLUTION PRIOR TO PROCEEDING WITH THE WORK.
- THE CONTRACTOR SHALL SUBMIT ALL PERTINENT SHOP DRAWINGS AND COLOR SAMPLES (INCLUDING CASEWORK) FOR THE ARCHITECT'S REVIEW. ALLOWING ADEQUATE TIME FOR REVIEW AND CORRECTIVE ACTION, SHOULD IT BE REQUIRED, BY SUBMITTING SHOP DRAWINGS. THE CONTRACTOR THEREBY REPRESENTS THAT HE HAS VERIFIED ALL FIELD MEASUREMENTS, METHODS OF ACCESS TO THE POINT OF INSTALLATION AND SIMILAR FIELD CRITERIA FOR CABINETS/MILLWORK AND ALL PREFABRICATED ASSEMBLIES OTHER THEN BUILDING STANDARD WORK.
- THE CONTRACTOR, AT HIS OWN EXPENSE, SHALL KEEP THE PROJECT AREA AND SURROUNDING AREA FREE FROM DUST NUISANCE. THE WORK SHALL BE IN CONFORMANCE WITH THE AIR POLLUTION CONTROL STANDARDS AND REGULATIONS OF THE STATE DEPARTMENT OF HEALTH AND AGENCIES.
- NO EXTRA WORK OR CHARGE SHALL BE MADE UNLESS WRITTEN AND COUNTERSIGNED BY THE ARCHITECT AND OWNER OR WRITTEN ORDER FROM THE ARCHITECT IS OBTAINED. THIS ORDER SHALL STATE THAT THE OWNER HAS AUTHORIZED THE EXTRA WORK OR CHARGE AND NO CLAIM FOR AN ADDITIONAL SUM SHALL BE VALID UNLESS SO PRESENTED AS DESCRIBED ABOVE.
- CONSTRUCTION DEBRIS AND WASTES SHALL BE DEPOSITED AT AN APPROPRIATE SITE. THE CONTRACTOR SHALL AT ALL TIMES, KEEP PREMISES FREE FROM ACCUMULATION OF DEBRIS CAUSED BY ITS OPERATIONS. AT THE COMPLETION OF THE WORK, THE CONTRACTOR SHALL CLEAN THE BUILDING AND LEAVE THE WORK "READY FOR MOPPING AND WAXING."
- GENERAL CONTRACTOR IS RESPONSIBLE FOR REVIEWING AND FIELD VERIFYING DEMOLITION REQUIREMENTS IN RELATION TO CONSTRUCTION DRAWINGS. THE ARCHITECT IS TO BE NOTIFIED OF ANY AND ALL CONFLICTS, DISCREPANCIES OR PROBLEMS.
- CONTRACTOR TO REPAIR AND PATCH ALL AREAS DISTURBED DUE TO THIS PROJECT'S SCOPE OF WORK.
- THE HEIGHT OF ANY NEW ACCESSIBLE WATER CLOSETS SHALL BE A MINIMUM OF 17" AND A MAXIMUM OF 19" AS MEASURED TO THE TOP OF THE TOILET SEAT. CONTROLS SHALL BE OPERABLE WITH ONE HAND AND SHALL NOT REQUIRE TIGHT GRASPING, PINCHING OR TWISTING OF THE WRIST. CONTROLS FOR FLUSH VALVES SHALL BE MOUNTED ON THE WIDE SIDE OF TOILET AREAS NO MORE THEN 44" ABOVE THE FLOOR. THE FORCE TO ACTIVATE THE CONTROLS SHALL BE NO GREATER THAN 5 POUNDS.
- ANY NEW ACCESSIBLE URINALS SHALL HAVE A RIM PROJECTING A MINIMUM OF 14" FROM THE WALL AND AT A MAXIMUM OF 17" ABOVE THE FLOOR. FLUSH CONTROLS SHALL BE HAND OPERATED AND SHALL BE MOUNTED NO MORE THAN 44" ABOVE THE FLOOR.
- WATER AND DRAIN PIPES UNDER LAVATORIES SHALL BE INSULATED OR OTHERWISE COVERED. THERE SHALL BE NO SHARP OR ABRASIVE SURFACES UNDER LAVATORIES.
- ANY NEW FAUCET CONTROLS AND OPERATING MECHANISMS SHALL BE OPERABLE WITH ONE HAND AND SHALL NOT REQUIRE TIGHT GRASPING, PINCHING OR TWISTING OF THE WRIST. THE FORCE REQUIRED TO ACTIVATE CONTROLS SHALL BE NO MORE THAN 5 POUNDS. LEVER-OPERATED, PUSH-TYPE AND ELECTRICALLY CONTROLLED MECHANISMS ARE EXAMPLES OF ACCEPTABLE DESIGNS. SELF-CLOSING VALVES ARE ALLOWED IF THE FAUCET REMAINS OPEN FOR AT LEAST 10 SECONDS.
- TOILET ROOM ACCESSIBLE DOOR IDENTIFICATION SYMBOLS ARE TO BE PROVIDED PER CCR, TITLE 24 AT ACCESSIBLE TOILET FACILITIES.
- ANY NEW DRINKING FOUNTAIN SHALL BE ACTIVATED BY A CONTROL WHICH IS EASILY OPERATED BY A PERSON W/ DISABILITIES SUCH AS A HAND-OPERATED LEVER TYPE CONTROL LOCATED WITHIN 6" OF THE FRONT OF THE DRINKING FOUNTAIN, ETC. THE BUBBLER SHALL BE SUBSTANTIALLY PARALLEL TO THE FRONT EDGE OF THE DRINKING FOUNTAIN.
- ALL NEW GYPNUM BOARD TO BE INSTALLED CONSISTENT WITH 2019 CBC SECTION 3108.
- ALL NEW GLAZING IS TO BE CONSISTENT WITH 2019 CBC CHAPTER 24
- ALL NEW EXIT DOORS SHALL BE OPERABLE FROM THE INSIDE WITHOUT THE USE OF A KEY OR ANY SPECIAL KNOWLEDGE OR EFFORT. NO DEADBOLTS, NO SLIDING BOLTS, ETC. (CBC SECTION 1010.1.9)
- ALL NEW HAND-ACTIVATED DOOR OPENING HARDWARE SHALL BE CENTERED BETWEEN 34" AND 44" ABOVE THE FLOOR. LOCKED DOORS THAT ARE HAND ACTIVATED AND WHICH ARE IN A PATH OF TRAVEL SHALL BE OPERABLE WITH A SINGLE EFFORT BY LEVER TYPE HARDWARE. LOCKED DOORS SHALL OPERATE AS ABOVE IN THE EGRESS DIRECTION.
- MAXIMUM EFFORT TO OPERATE ANY NEW DOORS SHALL NOT EXCEED 5 POUNDS FOR EXTERIOR DOORS AND 5 POUNDS FOR INTERIOR DOORS, SUCH PULL OR PUSH EFFORT BEING APPLIED AT RIGHT ANGLES TO HINGED DOORS AND AT THE CENTER PLANE OF SLIDING OR FOLDING DOORS. COMPENSATING DEVICES OR AUTOMATIC DOOR OPERATORS MAY BE UTILIZED TO MEET THE ABOVE STANDARDS. WHEN FIRE RATED DOORS ARE REQUIRED, THE MAXIMUM EFFORT TO OPERATE THE DOOR MAY BE INCREASED BUT NOT TO EXCEED 15 POUNDS, WHEN APPROVED BY LOCAL AUTHORITIES.
- THE BOTTOM 10" OF ALL NEW DOORS EXCEPT AUTOMATIC AND SLIDING DOORS SHALL HAVE A SMOOTH UNINTERRUPTED SURFACE TO ALLOW THE DOOR TO BE OPENED BY A WHEELCHAIR FOOTREST WITHOUT CREATING A TRAP OR HAZARDOUS CONDITION. WHERE NARROW FRAME DOORS ARE USED, A 10" HIGH SMOOTH PANEL SHALL BE INSTALLED ON THE PUSH SIDE OF THE DOOR, WHICH WILL ALLOW THE DOOR TO BE OPENED BY A WHEELCHAIR FOOTREST WITHOUT CREATING A TRAP OR HAZARDOUS CONDITION.
- ANY NEW DOORS AND FRAMES WITH 20 MINUTES TO AND INCLUDING 90 MINUTES RATINGS SHALL HAVE SMOKE SEAL, GASKETS AND SELF CLOSERS OR AUTOMATIC CLOSERS CONNECTED TO FIRE ALARM.
- WORK NOTED AS "OFCC" (OWNER-FURNISH, CONTRACTOR-INSTALL) SHALL MEET ALL APPLICABLE CODES & REGULATORY REQUIREMENTS, AND SHALL BE INSTALLED & FULLY OPERATIONAL PRIOR TO FINAL APPROVAL & OCCUPANCY OF THIS PROJECT
- PLUMBING FIXTURES AND FITTINGS SHALL MEET THE APPLICABLE STANDARDS REFERENCED IN TABLE 1701.1 OF THE 2019 CALIFORNIA PLUMBING CODE AND IN CHAPTER 6 OF CGC (CALIFORNIA GREEN BUILDING STANDARDS CODE). WATER EFFICIENCY REQUIREMENTS: PLUMBING FIXTURES (WATER CLOSETS AND URINALS) AND FITTINGS (FAUCETS, FOUNDATIONS, AND SHOWER-HEADS) SHALL COMPLY WITH THE PRESCRIPTIVE REDUCED FLOW RATES SPECIFIED IN CGC 5.303.2.3.1 THROUGH 5.303.45.303.3.1 THROUGH 5.303.3.4. TOILETS: MAX. 1.28 GALLONS PER FLUSH. URINALS: MAX. 0.125 GALLONS PER FLUSH. SHOWER-HEADS: MAX. FLOW RATE OF NOT MORE THAN 1.8 GALLONS PER MINUTE AT 80 PSI. LAVATORY FAUCETS: MAX. FLOW RATE OF NOT MORE THAN 0.5 GALLONS PER MINUTE AT 60 PSI. KITCHEN FAUCETS: MAX. FLOW RATE OF NOT MORE THAN 1.8 GALLONS PER MINUTE AT 60 PSI. KITCHEN FAUCETS MAY TEMPORARILY INCREASE THE FLOW ABOVE THE MAX RATE, BUT NOT TO EXCEED 2.2 GALLONS PER MINUTE AT 60 PSI. AND MUST DEFAULT TO A MAXIMUM FLOW RATE OF 1.8 GALLONS PER MINUTE AT 60 PSI. FOOD WASTE DISPOSERS: DISPOSERS SHALL EITHER MODULATE THE USE OF WATER TO NO MORE THAN 1 GPM WHEN THE DISPOSER IS NOT IN USE (NOT ACTIVELY GRINDING FOOD WASTE/NO-LOAD) OR SHALL AUTOMATICALLY SHUT OFF AFTER NO MORE THAN 10 MINUTES OF INACTIVITY. DISPOSERS SHALL USE NO MORE THAN 8 GPM OF WATER.
- CGC MECHANICAL REQUIREMENTS: THE PERMANENT HVAC SYSTEM SHALL ONLY BE USED DURING CONSTRUCTION IF NECESSARY TO CONDITION THE BUILDING OR AREAS OF ADDITION OR ALTERATION WITHIN THE REQUIRED TEMPERATURE RANGE FOR MATERIAL AND EQUIPMENT INSTALLATION. IF THE HVAC SYSTEM IS USED DURING CONSTRUCTION, USE RETURN AIR FILTERS WITH A MINIMUM EFFICIENCY REPORTING VALUE (MERV) OF 8, BASED ON ASHRAE 52.2-1999, OR AN AVERAGE EFFICIENCY OF 30 PERCENT BASED ON ASHRAE 52.1-1992. REPLACE ALL FILTERS IMMEDIATELY PRIOR TO OCCUPANCY, OR, IF THE BUILDING IS OCCUPIED DURING ALTERATION, AT THE CONCLUSION OF CONSTRUCTION. PER CGC 5.504.1
- AT THE TIME OF ROUGH INSTALLATION OR DURING STORAGE ON THE CONSTRUCTION SITE AND UNTIL FINAL STARTUP OF THE HEATING, COOLING AND VENTILATING EQUIPMENT, ALL DUCT AND OTHER RELATED AIR DISTRIBUTION COMPONENT OPENINGS SHALL BE COVERED WITH TAPE, PLASTIC, SHEET METAL OR OTHER METHODS ACCEPTABLE TO THE ENFORCING AGENCY TO REDUCE THE AMOUNT OF DUST OR DEBRIS WHICH MAY COLLECT IN THE SYSTEM. PER CGC 5.504.3.
- IN MECHANICALLY VENTILATED BUILDINGS, PROVIDE REGULARLY OCCUPIED AREAS OF THE BUILDING WITH AIR FILTRATION MEDIA FOR OUTSIDE AND RETURN AIR PRIOR TO OCCUPANCY THAT PROVIDES AT LEAST A MERV VALUE OF 13. MERV 13 FILTERS SHALL BE INSTALLED PRIOR TO OCCUPANCY, AND RECOMMENDATIONS FOR MAINTENANCE WITH FILTERS OF THE SAME VALUE SHALL BE INCLUDED IN THE OPERATION AND MAINTENANCE MANUAL. PER CGC 5.504.5.3.
- INDOOR MOISTURE CONTROL. BUILDINGS SHALL MEET OR EXCEED THE CBC TITLE 24, PART 2, SECTIONS 1203 (VENTILATION) AND CHAPTER 14 (EXTERIOR WALLS).
- INDOOR AIR QUALITY (5.506) OUTDOOR AIR DELIVERY. FOR ALL VENTILATED SPACES, MEET THE MINIMUM REQUIREMENTS OF SECTION 1201 (REQUIREMENTS FOR VENTILATION) OF THE 2019 CALIFORNIA ENERGY CODE, OR LOCAL CODE, WHICHEVER IS MORE STRINGENT.
- CARBON DIOXIDE (CO2) MONITORING. BUILDINGS EQUIPPED WITH DEMAND CONTROL VENTILATION, CO2 SENSORS AND VENTILATION CONTROLS SHALL BE SPECIFIED AND INSTALLED IN ACCORDANCE WITH THE 2019 CALIFORNIA ENERGY CODE SECTION 1201(C)(4).
- CGC MATERIALS REQUIREMENTS: FINISH MATERIALS SHALL COMPLY WITH SECTIONS CGC 5.504.4.1, THROUGH 5.504.4.6. ADHESIVES, SEALANTS AND CAULKS USED ON THE PROJECT SHALL MEET THE REQUIREMENTS OF THE STANDARDS LISTED IN CGC 5.504.4.1. ARCHITECTURAL PAINTS AND COATINGS SHALL COMPLY WITH TABLE CGC 5.504.4.3 UNLESS MORE STRINGENT LOCAL LIMITS APPLY.
- VERIFICATION, VERIFICATION OF COMPLIANCE WITH THIS SECTION SHALL BE PROVIDED AT THE REQUEST OF THE ENFORCING AGENCY.
- COMPOSITE WOOD PRODUCTS: HARDWOOD, PLYWOOD, PARTICLEBOARD AND MEDIUM DENSITY FIBERBOARD COMPOSITE WOOD PRODUCTS USED ON THE INTERIOR OR EXTERIOR OF THE BUILDING SHALL MEET THE REQUIREMENTS FOR FORMALDEHYDE AS SPECIFIED IN TABLE 5.504.4

Project Name:	803 Delaware	NRCC-PRF-01-E	Page 1 of 12
Project Address:	803 Delaware Street Berkeley 94710	Calculation Date/Time:	13:23, Fri, Aug 26, 2022
Input File Name:	803 Delaware lighting.cibd15x		

A. GENERAL INFORMATION			
1 Project Location (city)	Berkeley	8 Standards Version	Compliance2019
2 CA Zip Code	94710	9 Compliance Software (version)	EnergyPro 8.3
3 Climate Zone	3	10 Weather File	OAKLAND_724930_CZ2010.epw
4 Total Conditioned Floor Area In Scope	880 ft ²	11 Building Orientation (deg)	(S) 180 deg
5 Total Unconditioned Floor Area	0 ft ²	12 Permitted Scope of Work	ExistingAlteration
6 Total # of Stories (Habitable Above Grade)	1	13 Building Type(s)	Nonresidential
7 Total # of dwelling units	0	14 Gas Type	NaturalGas

B. PROJECT SUMMARY			
Table Instructions: Table B shows which building components are included in the performance calculation. If indicated as not included, the project must show compliance prescriptively if within permit application.			
Building Components Complying via Performance		Building Components Complying Prescriptively	
Envelope (see Table G)	<input checked="" type="checkbox"/> Performance <input type="checkbox"/> Not Included	Covered Process: Commercial Kitchens	<input type="checkbox"/> Performance <input checked="" type="checkbox"/> Not Included <i>The following building components are ONLY eligible for prescriptive compliance and should be documented on the NRCC form listed if within the scope of the permit application (i.e. compliance will not be shown on the NRCC-PRF-E).</i>
Mechanical (see Table H)	<input checked="" type="checkbox"/> Performance <input type="checkbox"/> Not Included	Covered Process: Computer Rooms	<input type="checkbox"/> Performance <input checked="" type="checkbox"/> Not Included Indoor Lighting (Unconditioned) \$140.6 NRCC-LTI-E Outdoor Lighting \$140.7 NRCC-LTO-E
Domestic Hot Water (see Table I)	<input checked="" type="checkbox"/> Performance <input type="checkbox"/> Not Included	Covered Process: Laboratory Exhaust	<input type="checkbox"/> Performance <input checked="" type="checkbox"/> Not Included Sign Lighting \$140.8 NRCC-LTS-E
Lighting (Indoor Conditioned, see Table K)	<input checked="" type="checkbox"/> Performance <input type="checkbox"/> Not Included		Electrical power systems, commissioning, solar ready, elevator and escalator requirements are mandatory and should be on the NRCC form listed if applicable (i.e. compliance will not be shown on the NRCC-PRF-E.) Electrical Power Distribution \$110.11 NRCC-ELC-E Commissioning \$120.8 NRCC-CXR-E Solar Ready \$110.10 NRCC-SRA-E
Solar Thermal Water Heating (see Table I)	<input type="checkbox"/> Performance <input checked="" type="checkbox"/> Not Included		

CA Building Energy Efficiency Standards- 2019 Nonresidential Compliance Report Version: NRCC-PRF-01-E-12092021-6844 Report Generated at: 2022-08-26 13:24:08

Project Name:	803 Delaware	NRCC-PRF-01-E	Page 2 of 12
Project Address:	803 Delaware Street Berkeley 94710	Calculation Date/Time:	13:23, Fri, Aug 26, 2022
Input File Name:	803 Delaware lighting.cibd15x		

C1. COMPLIANCE RESULTS FOR PERFORMANCE COMPONENTS (Annual TDV Energy Use, kBtu/ft²-yr)			
COMPLIES			
Energy Component	Standard Design (TDV)	Proposed Design (TDV)	Compliance Margin (TDV) ¹
Space Heating	43.09	66.24	-23.15
Space Cooling	88.64	24.78	63.86
Indoor Fans	266.42	43.95	222.47
Heat Rejection	--	--	--
Pumps & Misc.	--	--	--
Domestic Hot Water	26.31	21.31	5.00
Indoor Lighting	99.94	99.94	--
ENERGY STANDARDS COMPLIANCE TOTAL	524.40	256.22	268.18 (51.1%)
¹ Notes: The number in parenthesis following the Compliance Margin in column 4, represents the Percent Better than Standard.			

C2. RESULTS FOR 'ABOVE CODE' QUALIFICATIONS¹			
<input type="checkbox"/> This project is pursuing CalGreen Tier 1		<input type="checkbox"/> This project is pursuing CalGreen Tier 2	
Miscellaneous Energy Component	Standard Design (TDV)	Proposed Design (TDV)	Compliance Margin (TDV) ¹
Receptacle	105.29	105.29	--
Process	--	--	--
Other Ltg	--	--	--
Process Motors	--	--	--
COMPLIANCE TOTAL PLUS MISCELLANEOUS COMPONENTS	629.69	361.51	268.2 (42.6%)
¹ Notes: This table is used to document compliance with programs OTHER THAN Title 24 Part 6, if applicable.			

CA Building Energy Efficiency Standards- 2019 Nonresidential Compliance Report Version: NRCC-PRF-01-E-12092021-6844 Report Generated at: 2022-08-26 13:24:08

Project Name:	803 Delaware	NRCC-PRF-01-E	Page 3 of 12
Project Address:	803 Delaware Street Berkeley 94710	Calculation Date/Time:	13:23, Fri, Aug 26, 2022
Input File Name:	803 Delaware lighting.cibd15x		

C3. ENERGY USE SUMMARY						
Energy Component	Standard Design Site (MWh)	Proposed Design Site (MWh)	Margin (MWh)	Standard Design Site (MBtu)	Proposed Design Site (MBtu)	Margin (MBtu)
Space Heating	--	2.3	-2.3	19.4	--	19.4
Space Cooling	2.5	0.7	1.8	--	--	--
Indoor Fans	8.3	1.3	7.0	--	--	--
Heat Rejection	--	--	--	--	--	--
Pumps & Misc.	--	--	--	--	--	--
Domestic Hot Water	0.8	0.6	0.2	--	--	--
Indoor Lighting	3.0	3.0	0.0	--	--	--
Compliance Total	14.6	7.9	6.7	19.4	0.0	19.4
Receptacle	3.2	3.2	0.0	--	--	--
Process	--	--	--	--	--	--
Other Ltg	--	--	--	--	--	--
Process Motors	--	--	--	--	--	--
TOTAL	17.8	11.1	6.7	19.4	0.0	19.4

D. EXCEPTIONAL CONDITIONS						
This project uses the Simplified Geometry Performance Modeling Approach which is not capable of modeling daylighting controls and assumes the prescriptive Secondary Daylight Control requirements are met. PRESCRIPTIVE COMPLIANCE documentation (form NRCC-LTI-02-E) for the requirements of section 140.6(4) Automatic Daylighting Controls in Secondary Daylight Zones is required.						

E. HERS VERIFICATION						
This Section Does Not Apply						

CA Building Energy Efficiency Standards- 2019 Nonresidential Compliance Report Version: NRCC-PRF-01-E-12092021-6844 Report Generated at: 2022-08-26 13:24:08

Project Name:	803 Delaware	NRCC-PRF-01-E	Page 4 of 12
Project Address:	803 Delaware Street Berkeley 94710	Calculation Date/Time:	13:23, Fri, Aug 26, 2022
Input File Name:	803 Delaware lighting.cibd15x		

G1. ENVELOPE GENERAL INFORMATION (conditioned spaces only)			
1	2	3	4
Opaque Surfaces & Orientation	Total Gross Surface Area (ft ²)	Total Fenestration Area (ft ²)	Window to Wall Ratio (%)
North-Facing ¹	225 ft ²	16 ft ²	07.1%
East-Facing ²	540 ft ²	12 ft ²	02.1%
South-Facing ³	225 ft ²	53 ft ²	23.6%
West-Facing ⁴	540 ft ²	12 ft ²	02.1%
Total	1,530 ft ²	92 ft ²	06.0%
Roof	0 ft ²	0 ft ²	00.0%

Notes:
¹ North-Facing is oriented to within 45 degrees of true north, including 45°00'00" east of north (NE), but excluding 45°00'00" west of north (NW).
² East-Facing is oriented to within 45 degrees of true east, including 45°00'00" south of east (SE), but excluding 45°00'00" north of east (NE).
³ South-Facing is oriented to within 45 degrees of true south, including 45°00'00" west of south (SW), but excluding 45°00'00" east of south (SE).
⁴ West-Facing is oriented to within 45 degrees of true west, including 45°00'00" north of due west (NW), but excluding 45°00'00" south of west (SW).

G3. OPAQUE SURFACE ASSEMBLY SUMMARY									
1	2	3	4	5	6	7	8	9	10
Surface Name	Surface Type	Area (ft ²)	Framing Type	Cavity R-Value	Continuous R-Value	Units	Value	Description of Assembly Layers	Status
R-0 Floor Crawlspace ⁷	Exterior/Floor	880	NA	0	NA	U-Factor	0.166	Air - Floor - 3 1/2 in. Air - Cavity - Wall Roof Ceiling - 4 in. or more Plywood - 1/2 in. Carpet - 3/4 in.	E
R-0 Wall ⁹	Exterior/Wall	1530	NA	0	NA	U-Factor	0.300	Siding - Wood - bevel - 10 in. - lapped - 3/4 in. Vapor permeable felt - 1/8 in. Air - Cavity - Wall Roof Ceiling - 4 in. or more Gypsum Board - 1/2 in.	E

¹ Status: N - New, A - Altered, E - Existing

CA Building Energy Efficiency Standards- 2019 Nonresidential Compliance Report Version: NRCC-PRF-01-E-12092021-6844 Report Generated at: 2022-08-26 13:24:08

Project Name:	803 Delaware	NRCC-PRF-01-E	Page 5 of 12
Project Address:	803 Delaware Street Berkeley 94710	Calculation Date/Time:	13:23, Fri, Aug 26, 2022
Input File Name:	803 Delaware lighting.cibd15x		

G4. OPAQUE DOOR SUMMARY		
1	2	3
Assembly Name	Overall U-factor	Status ¹
Wood Door12	0.500	E

G5. FENESTRATION ASSEMBLY SUMMARY								
1	2	3	4	5	6	7	8	9
Fenestration Assembly Name / Tag or ID	Fenestration Type / Product Type / Frame Type	Certification Method ¹	Assembly Method	Area ft ²	Overall U-factor	Overall SHGC	Overall VT	Status
Single Wood Clear	VerticalFenestration FixedWindow NonMetalFraming	Default Performance	SiteBuilt	82	1.04	0.76	0.77	E
Single Non Metal Clear	VerticalFenestration FixedWindow NonMetalFraming	Default Performance	SiteBuilt	10	1.04	0.76	0.77	N

¹ Newly installed fenestration shall have a certified NRCC Label Certificate or use the CEC default tables found in Table 110.6-A and Table 110.6-B. Center of Glass (COG) values are for the glass-only, determined by the manufacturer, and are shown for ease of verification. Site-built fenestration values are calculated per Nonresidential Appendix NAB and are used in the analysis.
² Status: N - New, A - Altered, E - Existing

H1. DRY SYSTEM EQUIPMENT (Furnaces, air handling units, heat pumps, VR, economizers etc.)											
1	2	3	4	5	6	7	8	9	10	11	12
Equipment Name	Equipment Type	Qty	Total Heating Output (kBtu/h)	Supp Heat Output (kBtu/h)	Efficiency Unit	Efficiency	Total Cooling Output (kBtu/h)	Efficiency Unit	Efficiency	Economizer Type (if present)	Status
System 1	MiniSplitHP (Split3Phase)	2	19	0	HSPF	12.50	12	SEER/EEER	26.10 / 13.80	NA	N

¹ Status: N - New, A - Altered, E - Existing

CA Building Energy Efficiency Standards- 2019 Nonresidential Compliance Report Version: NRCC-PRF-01-E-12092021-6844 Report Generated at: 2022-08-26 13:24:08

Project Name:	803 Delaware	NRCC-PRF-01-E	Page 6 of 12
Project Address:	803 Delaware Street Berkeley 94710	Calculation Date/Time:	13:23, Fri, Aug 26, 2022
Input File Name:	803 Delaware lighting.cibd15x		

H2. FAN SYSTEMS SUMMARY														
1	2	3	4	5	6	7	8	9	10	11	12	13	14	
Name or Item Tag	Qty	Design OA	CFM	Modeling Method	Power	Control	CFM	Modeling Method	Power	Control	CFM	Modeling Method	Power	Control
System 1	2	0	400	BrakeHorsePower	0.092	bhp	ConstantVolume	NA	NA	NA	NA	NA	NA	N

¹ Status: N - New, A - Altered, E - Existing

H3. EXHAUST FAN SUMMARY							
1	2	3	4	5	6	7	8
System ID	Zone Name	Qty	CFM	Motor BHP	Power Per Flow (W/cfm)	Total Static Pressure (in. H ₂ O)	Status
Front3	3-Front	1	216	0.092	0.370	1.75	N

¹ Status: N - New, A - Altered, E - Existing

H4. Wet System Equipment(boilers,chillers,cooling towers,etc.)						
This Section Does Not Apply						

H5. PUMPS						
This Section Does Not Apply						

H6. SYSTEM SPECIAL FEATURES			
1	2	3	4
System Name	Equipment Type	Window Interlocks per \$140.4(n)	Other Special Features and Controls
DHW1 - SHW	Service Hot Water, Primary Only	NA	Fixed Temperature Control

Notes: This table includes controls related to the performance path only. For projects using the prescriptive path, mandatory and prescriptive controls requirements are documented on the NRCC-MCH-E.

CA Building Energy Efficiency Standards- 2019 Nonresidential Compliance Report Version: NRCC-PRF-01-E-12092021-6844 Report Generated at: 2022-08-26 13:24:08

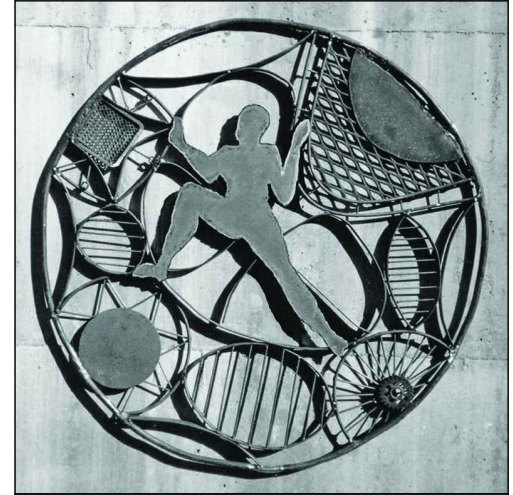

GUNKEL ARCHITECTURE
1295 59TH STREET
EMERYVILLE CA 94608
GUNKELARCHITECTURE.COM
PHONE: (510) 984 - 1112



RETAIL RENOVATION
803 DELAWARE STREET
BERKELEY, CA 94710

TITLE 24

BUILDING PERMIT

DATE 10/06/22

AO.2

Project Name:	803 Delaware	NRCC-PRF-01-E	Page 7 of 12
Project Address:	803 Delaware Street Berkeley 94710	Calculation Date/Time:	13:23, Fri, Aug 26, 2022
Input File Name:	803 Delaware lighting.cibd19x		

H7. NONRESIDENTIAL VENTILATION						
1	2	3	4	5	6	7
Zone Name	Mechanical Ventilation				Conditioned Area (sf)	DCV or Occupant Sensor Controls, or Both
	Ventilation Function	# of people	Supply OA CFM	Exhaust CFM		
1-Front	Retail - Sales	7.33	220	220	880	NA

H8. HIGH-RISE RESIDENTIAL DWELLING UNIT AND HOTEL/MOTEL VENTILATION												
This Section Does Not Apply												

H9. ZONAL SYSTEM AND TERMINAL UNIT SUMMARY												
1	2	3	4	5	6	7	8	9	10	11	12	13
System ID	Zone Name	System Type	Qty	Rated Capacity (kBtu/h)		Airflow (cfm)			Fan			
				Heating	Cooling	Design	Min.	Min. Ratio	Power	Power Units	Cycles	VSD
System 1	1-Front	MiniSplitHP	2	19.00	12.00	400	NA	NA	0.092	bhp	<input type="checkbox"/>	<input type="checkbox"/>

H10. EVAPORATIVE COOLER SUMMARY												
This Section Does Not Apply												

H11. HEAT RECOVERY SUMMARY												
This Section Does Not Apply												

CA Building Energy Efficiency Standards- 2019 Nonresidential Compliance Report Version: NRCC-PRF-01-E-12092021-6844 Report Generated at: 2022-08-26 13:24:08

Project Name:	803 Delaware	NRCC-PRF-01-E	Page 8 of 12
Project Address:	803 Delaware Street Berkeley 94710	Calculation Date/Time:	13:23, Fri, Aug 26, 2022
Input File Name:	803 Delaware lighting.cibd19x		

I1. WATER HEATER EQUIPMENT SUMMARY													
1	2	3	4	5	6	7	8	9	10	11	12	13	14
Name	Heater Element Type	Tank Type	Qty	Tank Vol (gal)	Rated Input	Rated Input Unit	Efficiency	Efficiency Unit	Tank Insulation R-value (Int/Ext)	Standby Loss Fraction	1st Hour Rating or Flow Rate (gal)	Heat Pump Type	Tank Location or Ambient Condition
BRADFORD WHITE REZ30LN**2	Electricity	Storage	1	26.00	4.5	kW	0.92	UEF	NA	NA	0	NA	NA

K1. INDOOR CONDITIONED LIGHTING GENERAL INFO					
1	2	3	4	5	6
Occupancy Type ¹	Conditioned Floor Area ² (ft ²)	Installed Lighting Power (Watts)	Lighting Control Credits (Watts)	Additional (Custom) Allowance	
Retail Sales Area (Retail Merchandise Sales)	880	880	0	Area Category Footnotes (Watts)	Tailored Method (Watts)
Building Totals:	880	880	0	0	0

¹ See Table 140.6-C
² See NRCC-01-01-6 for unconditioned spaces
³ Lighting information for existing spaces modeled is not included in the table

CA Building Energy Efficiency Standards- 2019 Nonresidential Compliance Report Version: NRCC-PRF-01-E-12092021-6844 Report Generated at: 2022-08-26 13:24:08

Project Name:	803 Delaware	NRCC-PRF-01-E	Page 9 of 12
Project Address:	803 Delaware Street Berkeley 94710	Calculation Date/Time:	13:23, Fri, Aug 26, 2022
Input File Name:	803 Delaware lighting.cibd19x		

K4. INDOOR CONDITIONED LIGHTING MANDATORY LIGHTING CONTROLS									
Building Level Controls									
1					2				
Mandatory Demand Response §110.12(c)					Shut-Off Controls §130.1(c)				
Area Level Controls (includes all lighting controls installed in conditioned space to meet mandatory requirements per §130.1)									
4	5	6	7	8	9	10			
Area Description	Area Category Primary Function Area	Area Controls §130.1(a)	Multi-Level Controls §130.1(b)	Shut-Off Controls §130.1(c)	Primary Daylighting §130.1(d)	Secondary Daylighting §140.5(d)			

CA Building Energy Efficiency Standards- 2019 Nonresidential Compliance Report Version: NRCC-PRF-01-E-12092021-6844 Report Generated at: 2022-08-26 13:24:08

Project Name:	803 Delaware	NRCC-PRF-01-E	Page 10 of 12
Project Address:	803 Delaware Street Berkeley 94710	Calculation Date/Time:	13:23, Fri, Aug 26, 2022
Input File Name:	803 Delaware lighting.cibd19x		

L. DECLARATION OF REQUIRED CERTIFICATES OF INSTALLATION	
Table Instructions: Selections shall be made by Documentation Author to indicate which Certificates of Installation must be submitted for the features to be recognized for compliance. These documents must be retained and provided to the building inspector during construction and can be found online at: https://www.energy.ca.gov/title24/2019standards/2019_compliance_documents/Nonresidential_Documents/NRCL/	
Building Component	Form/Title
Envelope	NRCA-ENV-01-E - Must be submitted for all buildings
Mechanical	NRCA-MCH-01-E - Must be submitted for all buildings
Plumbing	NRCA-PLB-01-E - Must be submitted for all buildings

CA Building Energy Efficiency Standards- 2019 Nonresidential Compliance Report Version: NRCC-PRF-01-E-12092021-6844 Report Generated at: 2022-08-26 13:24:08

Project Name:	803 Delaware	NRCC-PRF-01-E	Page 11 of 12
Project Address:	803 Delaware Street Berkeley 94710	Calculation Date/Time:	13:23, Fri, Aug 26, 2022
Input File Name:	803 Delaware lighting.cibd19x		

M. DECLARATION OF REQUIRED CERTIFICATES OF ACCEPTANCE	
Table Instructions: Selections shall be made by Documentation Author to indicate which Certificates of Acceptance must be submitted for the features to be recognized for compliance. These documents must be provided to the building inspector during construction and must be completed through an Acceptance Test Technician Certification Provider (ATTCP). For more information visit: https://www.energy.ca.gov/title24/2019standards/2019_compliance_documents/Nonresidential_Documents/NRCA/	
Building Component	Form/Title
Envelope	NRCA-ENV-02-F - NRFC label verification for fenestration
Mechanical	NRCA-MCH-02-A Outdoor Air must be submitted for all newly installed HVAC units. Note: MCH02-A can be performed in conjunction with MCH-07-A Supply Fan VFD Acceptance (if applicable) since testing activities overlap
	NRCA-MCH-03-A Constant Volume Single Zone HVAC
	NRCA-MCH-11-A Automatic Demand Shed Controls
	NRCA-MCH-13-A Automatic FDD for Air Handling Units and Zone Terminal Units Acceptance

CA Building Energy Efficiency Standards- 2019 Nonresidential Compliance Report Version: NRCC-PRF-01-E-12092021-6844 Report Generated at: 2022-08-26 13:24:08

Project Name:	803 Delaware	NRCC-PRF-01-E	Page 12 of 12
Project Address:	803 Delaware Street Berkeley 94710	Calculation Date/Time:	13:23, Fri, Aug 26, 2022
Input File Name:	803 Delaware lighting.cibd19x		

DOCUMENTATION AUTHOR'S DECLARATION STATEMENT	
I certify that the Certificates of Compliance documentation is accurate and complete.	
Documentation Author Name: Sharon Block	Signature:
Company: Bright Green Strategies, Inc.	Signature Date: 2022-08-26
Address: 820 Delaware Street	CEA/HERS Certification Identification (if applicable): 3074
City/State/Zip: Berkeley CA 94710	
Phone: 510-863-1109	

RESPONSIBLE PERSON'S DECLARATION STATEMENT	
I certify the following under penalty of perjury, under the laws of the State of California:	
1. The information provided on this Certificate of Compliance is true and correct.	
2. I am eligible under Division 3 of the Business and Professions Code to accept responsibility for the building design or system design identified on this Certificate of Compliance (responsible designer)	
3. The energy features and performance specifications, materials, components, and manufactured devices for the building design or system design identified on this Certificate of Compliance conform to the requirements of Title 24, Part 1 and Part 6 of the California Code of Regulations.	
4. The building design features or system design features identified on this Certificate of Compliance are consistent with the information provided on other applicable compliance documents, worksheets, calculations, plans and specifications submitted to the enforcement agency for approval with this building permit application.	
5. I will ensure that a completed signed copy of this Certificate of Compliance shall be made available with the building permit(s) issued for the building, and made available to the enforcement agency for all applicable inspections. I understand that a completed signed copy of this Certificate of Compliance is required to be included with the documentation the builder provides to the building owner at occupancy.	
Responsible Envelope Designer Name: Gunkel Architecture	Signature:
Company: Gunkel Architecture	Date Signed:
Address: 1295 59th Street	
City/State/Zip: Emeryville CA 94608	
Phone: 510-984-1112	Title: License #:
Responsible Lighting Designer Name:	Signature:
Company:	Date Signed:
Address:	
City/State/Zip:	Title: License #:
Phone:	
Responsible Mechanical Designer Name: - specify -	Signature:
Company:	Date Signed:
Address:	
City/State/Zip:	Title: License #:
Phone:	

CA Building Energy Efficiency Standards- 2019 Nonresidential Compliance Report Version: NRCC-PRF-01-E-12092021-6844 Report Generated at: 2022-08-26 13:24:08

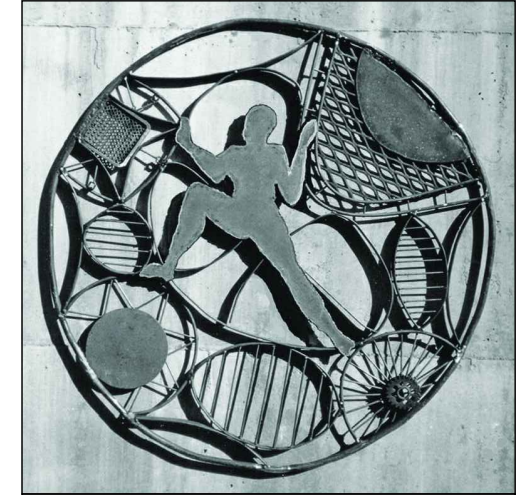

GUNKEL ARCHITECTURE
1295 59TH STREET
EMERYVILLE CA 94608
GUNKELARCHITECTURE.COM
PHONE: (510) 984 - 1112



RETAIL RENOVATION
803 DELAWARE STREET
BERKELEY, CA 94710

TITLE 24

BUILDING PERMIT

DATE 10/06/22

A0.3

STATE OF CALIFORNIA
Domestic Water Heating System
CALIFORNIA ENERGY COMMISSION

CERTIFICATE OF COMPLIANCE NRCC-PLB-E (Page 1 of 6)

This document is used to demonstrate compliance for nonresidential occupancies with requirements in §110.1, §110.3, §120.3, and §140.5, and with requirements in §141.0 for additions and alterations, for domestic water heating systems using the prescriptive path. For high-rise residential and hotel/motel occupancies compliance is demonstrated with requirements in §110.1, §110.3, §120.3, §150.0 and §150.1(c)(8), and with requirements §150.2 for additions.

Project Name: Retail Renovation Report Page: (Page 1 of 6)
Project Address: 803 Delaware Street Date Prepared: 8/26/2022

A. GENERAL INFORMATION

01 Project Location (City) Berkeley 02 Climate Zone 3

03 Occupancy Types Within Project (select all that apply):
 Nonresidential High-Rise Residential Hotel/Motel
 State Building Healthcare Facility Other (Write In)

B. PROJECT SCOPE

This table includes domestic water heating systems that are within the scope of the permit application and are demonstrating compliance using the prescriptive paths outlined in §140.5, §150.1(c)(8), and §141.0(a), or §141.0(b)(2) for additions or alterations. Solar water heating systems are documented on the NRCC-SRA compliance document. Combined hydronic water heating systems are documented on the NRCC-MCH compliance document.

01 My project consists of (check all that apply): 02 System Type^{1,2} 03 System Components

New system (DHW system being installed for the first time in newly constructed building) Individual System (serving nonresidential spaces) Equipment Distribution Controls
 System Alteration (equipment, distribution or controls) Equipment Distribution Controls

¹FOOTNOTES: Point of use water heaters, or other non-central systems used to serve nonresidential spaces, are considered individual systems.
² Dwelling units refers to hotel/motel guest rooms and units in a high-rise residential occupancy.

Registration Number: Registration Date/Time: Registration Provider: Energysoft
 CA Building Energy Efficiency Standards - 2019 Nonresidential Compliance Report Version: 2019.1.003 Schema Version: rev 20200601 Report Generated: 2022-08-26 13:32:50

STATE OF CALIFORNIA
Domestic Water Heating System
CALIFORNIA ENERGY COMMISSION

CERTIFICATE OF COMPLIANCE NRCC-PLB-E (Page 2 of 6)

Project Name: Retail Renovation Report Page: (Page 2 of 6)
Project Address: 803 Delaware Street Date Prepared: 8/26/2022

C. COMPLIANCE RESULTS

Table C will indicate if the project data input into the compliance document is compliant with water heating requirements. If this table says "DOES NOT COMPLY" or "COMPLIES with Exceptional Conditions" refer to Table D, or the table indicated as not compliant for guidance.

01	02	03	04
Domestic Hot Water Equipment	Distribution Systems	Controls	Compliance Results
Table F	Table G	Table H	
Yes	Yes	Yes	

COMPLIES

D. EXCEPTIONAL CONDITIONS

This table is auto-filled with uneditable comments because of selections made or data entered in tables throughout the form.

E. ADDITIONAL REMARKS

This table includes remarks made by the permit applicant to the Authority Having Jurisdiction.

Registration Number: Registration Date/Time: Registration Provider: Energysoft
 CA Building Energy Efficiency Standards - 2019 Nonresidential Compliance Report Version: 2019.1.003 Schema Version: rev 20200601 Report Generated: 2022-08-26 13:32:50

STATE OF CALIFORNIA
Domestic Water Heating System
CALIFORNIA ENERGY COMMISSION

CERTIFICATE OF COMPLIANCE NRCC-PLB-E (Page 3 of 6)

Project Name: Retail Renovation Report Page: (Page 3 of 6)
Project Address: 803 Delaware Street Date Prepared: 8/26/2022

F. DOMESTIC HOT WATER EQUIPMENT

This table is used to demonstrate compliance with mandatory equipment requirements in §110.1 and §110.3. For high-rise residential and hotel/motel occupancies, compliance with prescriptive requirements in §150.1(c)(8) must also be demonstrated and with §150.2 for addition and alteration scopes.

Equipment Schedule: Individual Systems

01	02	03	04	05	06
Name or Item Tag	Equipment Type	Volume (gal)	Max GPM/ First Hour Rating (FHR)	Rated Uniform Energy Factor (UEF)	Minimum Required Uniform Energy Factor (UEF) ¹
BRADFORD WHITE RE230LN* .*****	Electric Storage	<=30	0 <= FHR <18	0.92	0.86

¹FOOTNOTE: Compliant equipment may be found in the Modernized Appliance Efficiency Database System (MAEDBS) on the Energy Commission website: <https://cacertappliances.energy.ca.gov/Pages/Search/AdvancedSearch.aspx>

Water Heating Equipment All Occupancies

	Yes	No	Not Applicable	Requirement
18	<input type="checkbox"/>	<input type="checkbox"/>	<input checked="" type="checkbox"/>	Unfired storage tank insulation shall have Internal + External >=R-16 OR External >=R-12. Label required per §110.3(c)(3)
19	<input type="checkbox"/>	<input type="checkbox"/>	<input checked="" type="checkbox"/>	New state buildings 60% of energy for service water heating from site solar energy or recovered energy per §110.3(c)(5)
20	<input type="checkbox"/>	<input type="checkbox"/>	<input checked="" type="checkbox"/>	Isolation valves for instantaneous water heater with input rating >6.8 kBtu/h or 2 kW has been specified per §110.3(c)(6)

Registration Number: Registration Date/Time: Registration Provider: Energysoft
 CA Building Energy Efficiency Standards - 2019 Nonresidential Compliance Report Version: 2019.1.003 Schema Version: rev 20200601 Report Generated: 2022-08-26 13:32:50

STATE OF CALIFORNIA
Domestic Water Heating System
CALIFORNIA ENERGY COMMISSION

CERTIFICATE OF COMPLIANCE NRCC-PLB-E (Page 4 of 6)

Project Name: Retail Renovation Report Page: (Page 4 of 6)
Project Address: 803 Delaware Street Date Prepared: 8/26/2022

G. DOMESTIC HOT WATER DISTRIBUTION SYSTEM

This table is used to demonstrate compliance for nonresidential occupancies with distribution requirements in §120.3 and §140.5. For high-rise residential and hotel/motel occupancies, compliance is demonstrated with requirements §110.3(c), §120.3, §150.0, §150.1

Mandatory Pipe Insulation All Occupancies

12	<input checked="" type="checkbox"/>	For systems serving nonresidential spaces, pipe insulation for the following applications is specified to comply with Table 120.3-A (see below) per §120.3: <ul style="list-style-type: none"> Recirculating system piping, including supply and return piping of the water heater The first 8 ft of hot and cold outlet piping, including between storage tank and heat trap, for a nonrecirculating storage system Pipes that are externally heated
13	<input checked="" type="checkbox"/>	Insulation shall be protected from damage, including that due to sunlight, moisture, equipment maintenance, and wind. Insulation exposed to weather shall be installed with a cover suitable for outdoor service per §120.3(b) and §150.0(c)(3)

TABLE 120.3-A PIPE INSULATION THICKNESS

Fluid Temperature Range (°F)	Conductivity Range (Btu-in per hour per ft² per °F)	Insulation Mean Rating Temp (°F)	Nominal Pipe Diameter (in)		
			< 1	1 to < 1.5	1.5 to < 4
105-140	0.22 - 0.28	100	1.0 in or R-7	1.5 in or R-12.5	1.5 in or R-11

Registration Number: Registration Date/Time: Registration Provider: Energysoft
 CA Building Energy Efficiency Standards - 2019 Nonresidential Compliance Report Version: 2019.1.003 Schema Version: rev 20200601 Report Generated: 2022-08-26 13:32:50

STATE OF CALIFORNIA
Domestic Water Heating System
CALIFORNIA ENERGY COMMISSION

CERTIFICATE OF COMPLIANCE NRCC-PLB-E (Page 5 of 6)

Project Name: Retail Renovation Report Page: (Page 5 of 6)
Project Address: 803 Delaware Street Date Prepared: 8/26/2022

H. DOMESTIC HOT WATER CONTROLS

This table is used to demonstrate compliance with control requirements in §110.3 for all occupancies. For high-rise residential and hotel/motel occupancies, compliance is also demonstrated with requirements in §150.1(c)(8).

	Yes	No	Not Applicable	Requirement
01	<input checked="" type="checkbox"/>	<input type="checkbox"/>	<input type="checkbox"/>	Construction documents require manufacturer certification that service water-heating systems are equipped with automatic temperature controls capable of adjusting temperature settings per §110.3(a).
02	<input type="checkbox"/>	<input type="checkbox"/>	<input checked="" type="checkbox"/>	Systems with capacity > 167,000 BTUH equipped with outlet temperature controls per §110.3(c)(1) unless covered by California Plumbing Code 613.0.
03	<input type="checkbox"/>	<input type="checkbox"/>	<input checked="" type="checkbox"/>	Controls for circulating pumps or electrical heat trace systems are capable of automatically turning off the system per §110.3(c)(2) unless systems serves healthcare facility.
04	<input type="checkbox"/>	<input type="checkbox"/>	<input checked="" type="checkbox"/>	For recirculation systems serving multiple dwelling units, design includes automatic pump controls per §150.1(c)(8)(ii), or §150.2 for additions or alterations.
05	<input type="checkbox"/>	<input type="checkbox"/>	<input checked="" type="checkbox"/>	For recirculation systems serving individual dwelling units, design includes manual on/off controls as specified in Reference Appendix RAA.4.9 per §150.1(c)(8).
06	<input type="checkbox"/>	<input type="checkbox"/>	<input checked="" type="checkbox"/>	For replacement single heat pump water heaters serving individual dwelling units in climate zone 1-15, design includes communication interface that meets demand responsive control requirements of §110.12(a), per §150.2(b)(1)(iii).

I. DECLARATION OF REQUIRED CERTIFICATES OF INSTALLATION

Selections have been made based on information provided in this document. If any selection has been changed by permit applicant, an explanation should be included in Table E.

Additional Remarks: These documents must be provided to the building inspector during construction and can be found online at https://www.energy.ca.gov/title24/2019standards/2019_compliance_documents/Nonresidential_Documents/NRCC/

Form/Title	Field Inspector
Pass	Fail
NRCC-PLB-01-E - Must be submitted for all buildings	<input type="checkbox"/> <input type="checkbox"/>

J. DECLARATION OF REQUIRED CERTIFICATES OF ACCEPTANCE

There are no Certificates of Acceptance applicable to service water heating requirements.

K. DECLARATION OF REQUIRED CERTIFICATES OF VERIFICATION

There are no NRCC forms required for this project.

Registration Number: Registration Date/Time: Registration Provider: Energysoft
 CA Building Energy Efficiency Standards - 2019 Nonresidential Compliance Report Version: 2019.1.003 Schema Version: rev 20200601 Report Generated: 2022-08-26 13:32:50

STATE OF CALIFORNIA
Domestic Water Heating System
CALIFORNIA ENERGY COMMISSION

CERTIFICATE OF COMPLIANCE NRCC-PLB-E (Page 6 of 6)

Project Name: Retail Renovation Report Page: (Page 6 of 6)
Project Address: 803 Delaware Street Date Prepared: 8/26/2022

DOCUMENTATION AUTHOR'S DECLARATION STATEMENT

I certify that this Certificate of Compliance documentation is accurate and complete.

Documentation Author Name: Sharon Block
 Company: Bright Green Strategies, Inc.
 Address: 820 Delaware Street
 City/State/Zip: Berkeley CA 94710
 Phone: 510-863-1109

Signature Date: 2022-08-26
 CEAH/HERS Certification Identification (if applicable): 3074

RESPONSIBLE PERSON'S DECLARATION STATEMENT

I certify the following under penalty of perjury under the laws of the State of California:

- The information provided on this Certificate of Compliance is true and correct.
- I am eligible under Division 3 of the Business and Professions Code to accept responsibility for the building design or system design identified on this Certificate of Compliance (responsible designer).
- The energy features and performance specifications, materials, components, and manufactured devices for the building design or system design identified on this Certificate of Compliance conform to the requirements of Title 24, Part 1 and Part 6 of the California Code of Regulations.
- The building design features or system design features identified on this Certificate of Compliance are consistent with the information provided on other applicable compliance documents, worksheets, calculations, plans and specifications submitted to the enforcement agency for approval with this building permit application.
- I will ensure that a completed signed copy of this Certificate of Compliance shall be made available with the building permit(s) issued for the building, and made available to the enforcement agency for all applicable inspections. I understand that a completed signed copy of this Certificate of Compliance is required to be included with the documentation the builder provides to the building owner at occupancy.

Responsible Designer Name: AMBER BAKER
 Company: GUNKEL ARCHITECTURE
 Address: 1295 59TH ST.
 City/State/Zip: EMERYVILLE, CA 94608

Responsible Designer Signature: Amber Baker
 Date Signed: 2022-08-26
 License: C 37581
 Phone: (510) 984-1112 X 106

Registration Number: Registration Date/Time: Registration Provider: Energysoft
 CA Building Energy Efficiency Standards - 2019 Nonresidential Compliance Report Version: 2019.1.003 Schema Version: rev 20200601 Report Generated: 2022-08-26 13:32:50



GUNKEL ARCHITECTURE
 1295 59TH STREET
 EMERYVILLE CA 94608
 GUNKELARCHITECTURE.COM
 PHONE: (510) 984 - 1112



RETAIL RENOVATION
 803 DELAWARE STREET
 BERKELEY, CA 94710

TITLE 24

BUILDING PERMIT

DATE 10/06/22

A0.4

HVAC SYSTEM HEATING AND COOLING LOADS SUMMARY			
Project Name Retail Renovation		Date 8/26/2022	
System Name System 1		Floor Area 880	
ENGINEERING CHECKS		SYSTEM LOAD	
Number of Systems	2		
Heating System		COIL COOLING PEAK	
Output per System	18,000	CFM	Sensible
Total Output (Btuh)	36,000	1,347	24,330
Output (Btuh/sqft)	40.9		2,933
Cooling System		COIL HTG. PEAK	
Output per System	12,000	CFM	Sensible
Total Output (Btuh)	24,000	220	1,217
Total Output (Tons)	2.0		0
Total Output (Btuh/sqft)	27.3		0
Total Output (sqft/Ton)	440.0		0
Air System		TOTAL SYSTEM LOAD	
CFM per System	400		29,086
Airflow (cfm)	800		1,513
Airflow (cfm/sqft)	0.91		
Airflow (cfm/Ton)	400.0		
Outside Air (%)	27.5%		
Outside Air (cfm/sqft)	0.25		
HVAC EQUIPMENT SELECTION			
Mitsubishi MSZ-FS 12		23,745	0
Total Adjusted System Output		26,896	
(Adjusted for Peak Design conditions)			
TIME OF SYSTEM PEAK		Aug 3 PM	
		Jan 1 AM	
Note: values above given at ARI conditions			
HEATING SYSTEM PSYCHROMETRICS (Airstream Temperatures at Time of Heating Peak)			
COOLING SYSTEM PSYCHROMETRICS (Airstream Temperatures at Time of Cooling Peak)			

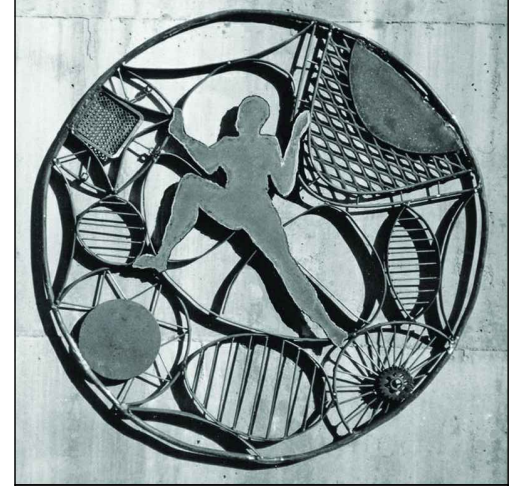

GUNKEL ARCHITECTURE
1295 59TH STREET
EMERYVILLE CA 94608
GUNKELARCHITECTURE.COM
PHONE: (510) 984 - 1112



RETAIL RENOVATION
803 DELAWARE STREET
BERKELEY, CA 94710

TITLE 24

BUILDING PERMIT

DATE 10/06/22

A0.5

STATE OF CALIFORNIA
Indoor Lighting
NRCC-LTI-E CALIFORNIA ENERGY COMMISSION

CERTIFICATE OF COMPLIANCE NRCC-LTI-E
This document is used to demonstrate compliance with requirements in §110.9, §110.12(c), §130.0, §130.1, §140.6, and §141.0(b)2 for indoor lighting scopes using the prescriptive path.
Project Name: Retail Renovation Report Page: (Page 1 of 7)
Project Address: 803 Delaware Street Date Prepared: 8/26/2022

A. GENERAL INFORMATION

01 Project Location (city)	Berkeley	04 Total Conditioned Floor Area (ft ²)	880
02 Climate Zone	3	05 Total Unconditioned Floor Area (ft ²)	0
03 Occupancy Types Within Project (select all that apply):		06 # of Stories (Habitable Above Grade)	1

• Retail • Support Areas

B. PROJECT SCOPE
This table includes any lighting systems that are within the scope of the permit application and are demonstrating compliance using the prescriptive path outlined in §140.6 or §141.0(b)2 for alterations.

Scope of Work	Conditioned Spaces	Unconditioned Spaces
01	02	03
My Project Consists of (check all that apply):	Calculation Method	Area (ft ²)
<input type="checkbox"/> New Lighting System		
<input type="checkbox"/> New Lighting System - Parking Garage		
<input checked="" type="checkbox"/> Altered Lighting System	Area Category Method	880
	Area Category Method	0
Total Area of Work (ft²)		880

STATE OF CALIFORNIA
Indoor Lighting
NRCC-LTI-E CALIFORNIA ENERGY COMMISSION

C. COMPLIANCE RESULTS
If any cell on this table says "DOES NOT COMPLY" or "COMPLIES with Exceptional Conditions" refer to Table D, for guidance.

Lighting in conditioned and unconditioned spaces must not be combined for compliance per §140.6(b)1	Allowed Lighting Power per §140.6(b) (Watts)				05	Adjusted Lighting Power per §140.6(a) (Watts)			Compliance Results		
	01 Complete Building §140.6(c)1	02 Area Category §140.6(c)2	03 Area Category Additional §140.6(c)2G (+)	04 Tailored §140.6(c)3 (+)		06 Total Designed (Watts)	07 PAF Lighting Control Credits §140.6(a)2 (-)	08 Total Adjusted (Watts) *Includes Adjustments			
(See Table I)	(See Table I)	(See Table J)	(See Table K)	=	812	≥	(See Table F)	(See Table P)	=	806	05 must be ≥ 08 §140.6
Conditioned	811.8	0		=	812	≥	896	90	=	806	COMPLIES
Unconditioned				=		≥			=		COMPLIES
Controls Compliance (See Table H for Details)										COMPLIES	
Rated Power Reduction Compliance (See Table Q for Details)										COMPLIES	

D. EXCEPTIONAL CONDITIONS
This table is auto-filled with uneditable comments because of selections made or data entered in tables throughout the form.

E. ADDITIONAL REMARKS
This table includes remarks made by the permit applicant to the Authority Having Jurisdiction.

F. INDOOR LIGHTING FIXTURE SCHEDULE
This table includes all permanent designed lighting and all portable lighting in offices.

Designed Wattage: Conditioned Spaces

01	02	03	04	05	06	07	08	09	10
Name or Item Tag	Complete Luminaire Description	Modular (Track) Fixture	Small Aperture & Color Change ¹	Watts per luminaire ²	How is Wattage determined	Total Number of Luminaires	Excluded per §140.6(a)3	Design Watts	Field Inspector
P1	LED 2	No	No	64	Mfr. Spec	2	No	128	<input type="checkbox"/> Pass <input type="checkbox"/> Fail
P2	LED 2	No	No	64	Mfr. Spec	2	No	128	<input type="checkbox"/> Pass <input type="checkbox"/> Fail

Registration Number: Registration Date/Time: Registration Provider: Energysoft
CA Building Energy Efficiency Standards - 2019 Nonresidential Compliance Report Version: 2019.1.003 Schema Version: rev 20200601 Report Generated: 2022-08-26 17:18:05

STATE OF CALIFORNIA
Indoor Lighting
NRCC-LTI-E CALIFORNIA ENERGY COMMISSION

F. INDOOR LIGHTING FIXTURE SCHEDULE

R1	R2	R3	LED	No	No	32	Mfr. Spec	12	No	384	<input type="checkbox"/>	<input type="checkbox"/>
			LED3	No	No	48	Mfr. Spec	4	No	192	<input type="checkbox"/>	<input type="checkbox"/>
			LED	No	No	32	Mfr. Spec	2	No	64	<input type="checkbox"/>	<input type="checkbox"/>
Total Designed Watts: CONDITIONED SPACES										896		

¹FOOTNOTE: Design Watts for small aperture and color changing luminaires which qualify per §140.6(a)4B is adjusted to be 75% of their rated wattage. Table F automatically makes this adjustment, the permit applicant should enter full rated wattage in column 05.
²Authority Having Jurisdiction may ask for luminaire cut sheets to confirm wattage used for compliance per §130.0(c). Wattage used must be the maximum rated for the luminaire, not the lamp.

G. MODULAR LIGHTING SYSTEMS
This section does not apply to this project.

H. INDOOR LIGHTING CONTROLS (Not including PAFs)
This table includes lighting controls for conditioned and unconditioned spaces. When a control having a * is shown, the notes section of this table provides more detail on how compliance is achieved. The lighting controls section of the Compliance Summary Table on the first page will show "DOES NOT COMPLY" if the notes are left blank.

Building Level Controls

01	02	03
Mandatory Demand Response §110.12(c)	Shut-off controls §130.1(c)	Field Inspector
Required > 10,000 SF	Whole Building Auto Time Switch	Pass Fail
		<input type="checkbox"/> <input type="checkbox"/>

Area Level Controls

04	05	06	07	08	09	10	11	12
Area Description	Complete Building or Area Category Primary Function Area	Area Controls §130.1(a)	Multi-Level Controls §130.1(b)	Shut-Off Controls §130.1(c)	Primary/Sky lit Daylighting §130.1(d)	Secondary Daylighting §140.6(d)	Interlocked Systems §140.6(a)1	Field Inspector
								Pass Fail

Registration Number: Registration Date/Time: Registration Provider: Energysoft
CA Building Energy Efficiency Standards - 2019 Nonresidential Compliance Report Version: 2019.1.003 Schema Version: rev 20200601 Report Generated: 2022-08-26 17:18:05

STATE OF CALIFORNIA
Indoor Lighting
NRCC-LTI-E CALIFORNIA ENERGY COMMISSION

CERTIFICATE OF COMPLIANCE NRCC-LTI-E
Project Name: Retail Renovation Report Page: (Page 4 of 7)
Project Address: 803 Delaware Street Date Prepared: 8/26/2022

H. INDOOR LIGHTING CONTROLS (Not including PAFs)
*NOTES: Controls with a * require a note in the space below explaining how compliance is achieved.
Ex: Conference 1: Primary/Skylight Daylighting: Exempt because less than 120 watts of general lighting; EXCEPTION 1 to §130.1(d)2
Plan Sheet Showing Daylit Zones: 13

I. LIGHTING POWER ALLOWANCE: COMPLETE BUILDING OR AREA CATEGORY METHODS
Each area complying using the Complete Building or Area Category Methods per §140.6(b) are included in this table. Column 06 indicates if additional lighting power allowances per §140.6(c) or adjustments per §140.6(a) are being used.

Conditioned Spaces

01	02	03	04	05	06
Area Description	Complete Building or Area Category Primary Function Area	Allowed Density (W/ft ²)	Area (ft ²)	Allowed Wattage (Watts)	Additional Allowance / Adjustment
Front	Retail Merchandise Sales	1	685	685	No Yes
Back	Restrooms	0.65	195	126.8	No Yes
TOTALS:			880	811.8	See Tables J, or P for detail

STATE OF CALIFORNIA
Indoor Lighting
NRCC-LTI-E CALIFORNIA ENERGY COMMISSION

CERTIFICATE OF COMPLIANCE NRCC-LTI-E
Project Name: Retail Renovation Report Page: (Page 5 of 7)
Project Address: 803 Delaware Street Date Prepared: 8/26/2022

O. ADDITIONAL LIGHTING ALLOWANCE: TAILORED VERY VALUABLE MERCHANDISE
This section does not apply to this project.

P. POWER ADJUSTMENT: LIGHTING CONTROL CREDIT (POWER ADJUSTMENT FACTOR (PAF))
This table includes all areas indicated in Table I or Table K as using a PAF credit described in §140.6(a)2.

Conditioned Spaces

Area Description	PAF per §140.6(a)2 ¹							Luminaires Controlled for PAF Credit			Lighting Controlled (Watts)	Control Credit Power Adjustments (Watts)		
	1	2A	2B	2C	3A	3B	4	5	6	7			Luminaire Name or Item Tag	Luminaire Design Watts
Front	<input checked="" type="checkbox"/>	<input type="checkbox"/>	<input type="checkbox"/>	<input type="checkbox"/>	<input type="checkbox"/>	<input type="checkbox"/>	<input type="checkbox"/>	<input type="checkbox"/>	<input type="checkbox"/>	<input type="checkbox"/>	R1	32	10	320
Front	<input checked="" type="checkbox"/>	<input type="checkbox"/>	<input type="checkbox"/>	<input type="checkbox"/>	<input type="checkbox"/>	<input type="checkbox"/>	<input type="checkbox"/>	<input type="checkbox"/>	<input type="checkbox"/>	<input type="checkbox"/>	R2	48	4	192
Front	<input checked="" type="checkbox"/>	<input type="checkbox"/>	<input type="checkbox"/>	<input type="checkbox"/>	<input type="checkbox"/>	<input type="checkbox"/>	<input type="checkbox"/>	<input type="checkbox"/>	<input type="checkbox"/>	<input type="checkbox"/>	P1	64	2	128
Front	<input checked="" type="checkbox"/>	<input type="checkbox"/>	<input type="checkbox"/>	<input type="checkbox"/>	<input type="checkbox"/>	<input type="checkbox"/>	<input type="checkbox"/>	<input type="checkbox"/>	<input type="checkbox"/>	<input type="checkbox"/>	P2	64	2	128
Back	<input checked="" type="checkbox"/>	<input type="checkbox"/>	<input type="checkbox"/>	<input type="checkbox"/>	<input type="checkbox"/>	<input type="checkbox"/>	<input type="checkbox"/>	<input type="checkbox"/>	<input type="checkbox"/>	<input type="checkbox"/>	R1	32	2	64
Back	<input checked="" type="checkbox"/>	<input type="checkbox"/>	<input type="checkbox"/>	<input type="checkbox"/>	<input type="checkbox"/>	<input type="checkbox"/>	<input type="checkbox"/>	<input type="checkbox"/>	<input type="checkbox"/>	<input type="checkbox"/>	R3	32	2	64

¹ FOOTNOTES: PAFs outlined in Table 140.6-A include 1) Daylight dimming plus OFF; 2A) Occupant sensors in offices [alte/] 125 ft²; 2B) Occupant sensors in offices 126 - 250 ft²; 2C) Occupant sensors in offices 251 - 500 ft²; 3A) Institutional tuning, non-daylit areas and 3B) Institutional tuning, daylit areas; 4) Demand response; 5) Clerestory penetration; 6) Horizontal slats; 7) Light shelves.

Q. RATED POWER REDUCTION COMPLIANCE FOR ALTERATIONS
This section does not apply to this project.

R. 80% LIGHTING POWER FOR ALL ALTERATIONS - CONTROLS EXCEPTIONS
This section does not apply to this project.

Registration Number: Registration Date/Time: Registration Provider: Energysoft
CA Building Energy Efficiency Standards - 2019 Nonresidential Compliance Report Version: 2019.1.003 Schema Version: rev 20200601 Report Generated: 2022-08-26 17:18:05

STATE OF CALIFORNIA
Indoor Lighting
NRCC-LTI-E CALIFORNIA ENERGY COMMISSION

CERTIFICATE OF COMPLIANCE NRCC-LTI-E
Project Name: Retail Renovation Report Page: (Page 6 of 7)
Project Address: 803 Delaware Street Date Prepared: 8/26/2022

S. DAYLIGHT DESIGN POWER ADJUSTMENT FACTOR (PAF)
This table documents clerestories, horizontal slats or light shelves meet the requirements in §140.3(d). If a Power Adjustment Factor was claimed on Table P, these features must be documented on the architectural plans or where appropriate within the construction documents. This PAF also must be verified in the field with an acceptance test per Table U.

01 Compliance Strategy

T. DECLARATION OF REQUIRED CERTIFICATES OF INSTALLATION
Selections have been made based on information provided in this document. If any selection have been changed by permit applicant, an explanation should be included in Table E. Additional Remarks. These documents must be provided to the building inspector during construction and can be found online at https://www.energy.ca.gov/title24/2019standards/2019_compliance_documents/Nonresidential_Documents/NRCL/

Form/Title	Field Inspector
	Pass Fail
NRCL-TI-01-E - Must be submitted for all buildings	<input type="checkbox"/> <input type="checkbox"/>
NRCL-TI-05-E - Must be submitted for a Power Adjustment Factor (PAF) to be recognized for compliance.	<input type="checkbox"/> <input type="checkbox"/>

U. DECLARATION OF REQUIRED CERTIFICATES OF ACCEPTANCE
Selections have been made based on information provided in this document. If any selection have been changed by the permit applicant, an explanation should be included in Table E. Additional Remarks. These documents must be provided to the building inspector during construction and any with "A" in the form name must be completed through an Acceptance Test Technician Certification Provider (ATTCP). For more information visit: http://www.energy.ca.gov/title24/attcp/providers.html

Form/Title	Systems/Spaces To Be Field Verified	Field Inspector
NRCA-LTI-02-A - Must be submitted for occupancy sensors and automatic time switch controls.	<input type="checkbox"/> <input type="checkbox"/>	Pass Fail
NRCA-LTI-04-A - Must be submitted for demand responsive lighting controls.	<input type="checkbox"/> <input type="checkbox"/>	Pass Fail

Registration Number: Registration Date/Time: Registration Provider: Energysoft
CA Building Energy Efficiency Standards - 2019 Nonresidential Compliance Report Version: 2019.1.003 Schema Version: rev 20200601 Report Generated: 2022-08-26 17:18:05

Registration Number: Registration Date/Time: Registration Provider: Energysoft
CA Building Energy Efficiency Standards - 2019 Nonresidential Compliance Report Version: 2019.1.003 Schema Version: rev 20200601 Report Generated: 2022-08-26 17:18:05

Registration Number: Registration Date/Time: Registration Provider: Energysoft
CA Building Energy Efficiency Standards - 2019 Nonresidential Compliance Report Version: 2019.1.003 Schema Version: rev 20200601 Report Generated: 2022-08-26 17:18:05

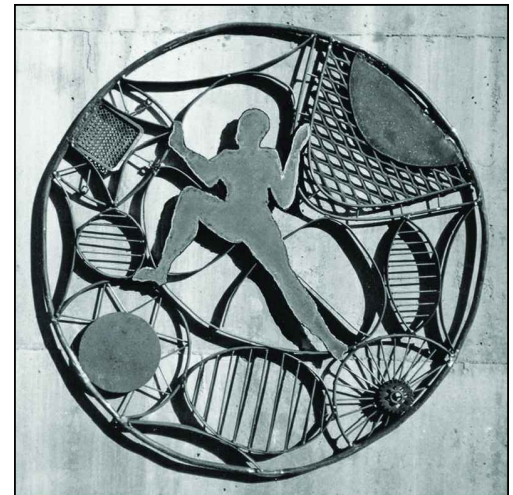

GUNKEL ARCHITECTURE
1295 59TH STREET
EMERYVILLE CA 94608
GUNKELARCHITECTURE.COM
PHONE: (510) 984 - 1112



RETAIL RENOVATION
803 DELAWARE STREET
BERKELEY, CA 94710

TITLE 24

BUILDING PERMIT

DATE 10/06/22

A0.6

STATE OF CALIFORNIA
Indoor Lighting CALIFORNIA ENERGY COMMISSION
NRCC-LTI-6

CERTIFICATE OF COMPLIANCE	Retail Renovation	Report Page: (Page 7 of 7)
Project Name:	803 Delaware Street	Date Prepared: 8/26/2022

DOCUMENTATION AUTHOR'S DECLARATION STATEMENT
I certify that this Certificate of Compliance documentation is accurate and complete.

Documentation Author Name: Sharon Block	Documentation Author Signature:
Company: Bright Green Strategies, Inc.	Signature Date:
Address: 820 Delaware Street	CEA/ NERS Certification Identification (if applicable): 3074
City/State/Zip: Berkeley CA 94710	Phone: 510-863-1109

RESPONSIBLE PERSON'S DECLARATION STATEMENT
I certify the following under penalty of perjury, under the laws of the State of California:

- The information provided on this Certificate of Compliance is true and correct.
- I am eligible under Division 3 of the Business and Professions Code to accept responsibility for the building design or system design identified on this Certificate of Compliance (responsible designer).
- The energy features and performance specifications, materials, components, and manufactured devices for the building design or system design identified on this Certificate of Compliance conform to the requirements of Title 24, Part 1 and Part 6 of the California Code of Regulations.
- The building design features or system design features identified on this Certificate of Compliance are consistent with the information provided on other applicable compliance documents, worksheets, calculations, plans and specifications submitted to the enforcement agency for approval with this building permit application.
- I will ensure that a completed signed copy of this Certificate of Compliance shall be made available with the building permit(s) issued for the building, and made available to the enforcement agency for all applicable inspections. I understand that a completed signed copy of this Certificate of Compliance is required to be included with the documentation the builder provides to the building owner at occupancy.

Responsible Designer Name: Gunkel Architecture	Responsible Designer Signature: <i>Amber Lee Baker</i>
Company: Gunkel Architecture	Date Signed: 2022-08-26
Address: 1295 59TH ST.	License: C 37581
City/State/Zip: EMERYVILLE, CA 94608	Phone: (510) 984-1112 X 106

Registration Number: CA Building Energy Efficiency Standards - 2019 Nonresidential Compliance
Registration Date/Time: Report Version: 2019.1.003
Registration Provider: Energysoft
Schema Version: rev 20200601
Report Generated: 2022-08-26 17:18:05

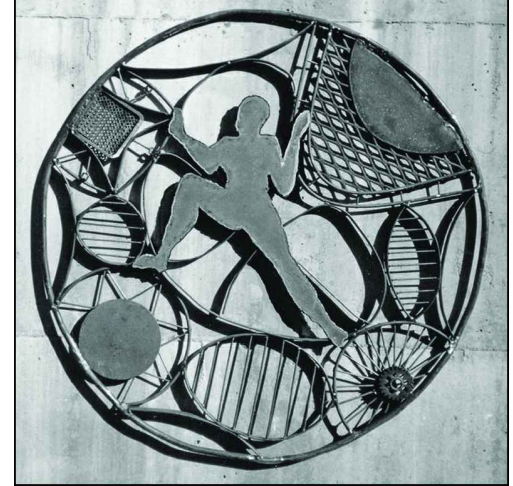

GUNKEL ARCHITECTURE
1295 59TH STREET
EMERYVILLE CA 94608
GUNKELARCHITECTURE.COM
PHONE: (510) 984 - 1112



RETAIL RENOVATION
803 DELAWARE STREET
BERKELEY, CA 94710

TITLE 24

BUILDING PERMIT

DATE 10/06/22

A0.7

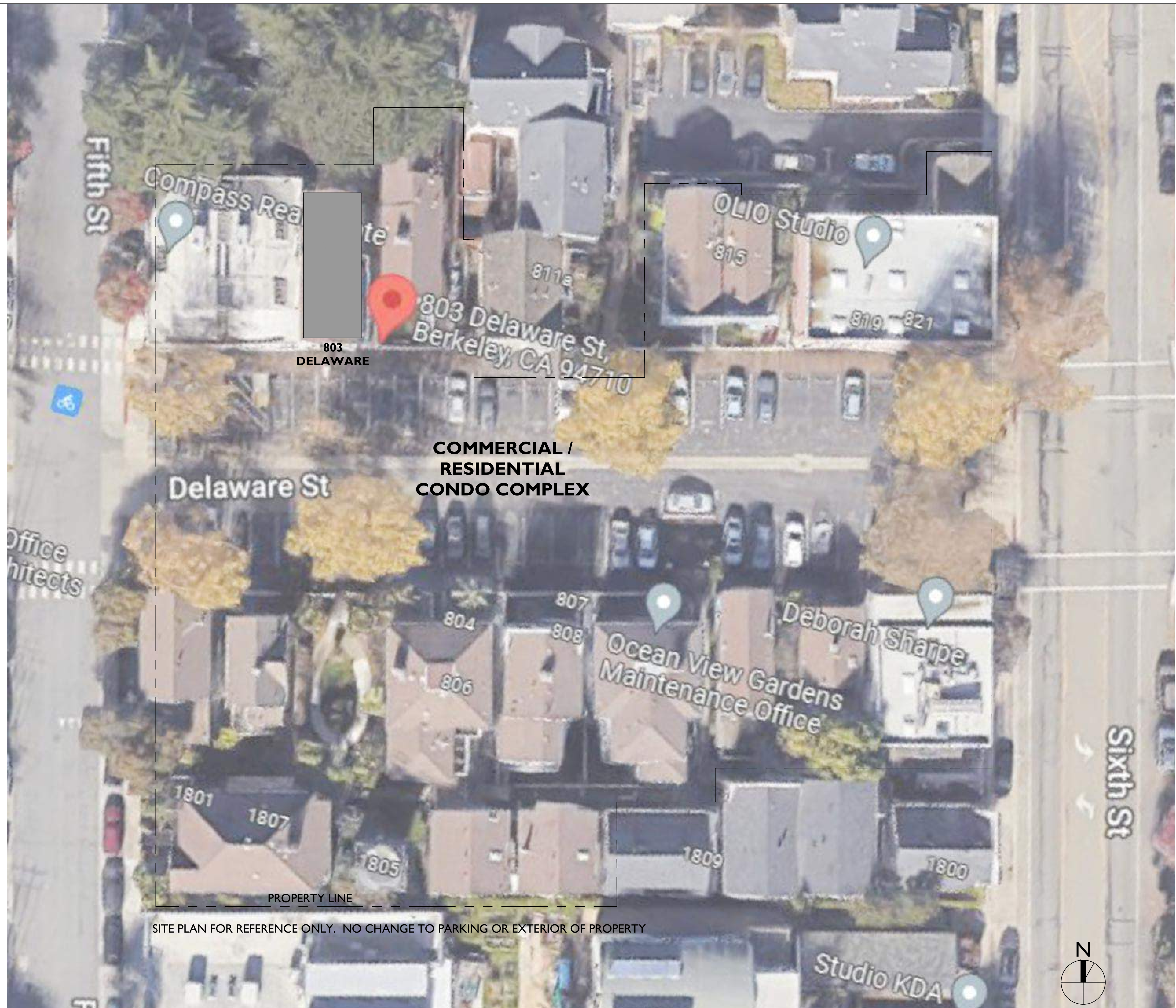

SITE PLAN FOR REFERENCE ONLY. NO CHANGE TO PARKING OR EXTERIOR OF PROPERTY

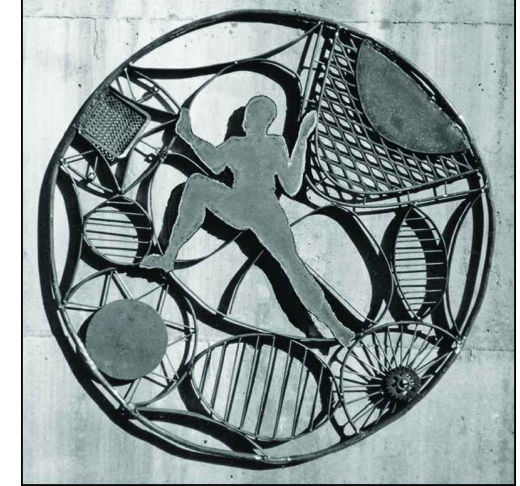

GUNKEL ARCHITECTURE
 1295 59TH STREET
 EMERYVILLE CA 94608
 GUNKELARCHITECTURE.COM
 PHONE: (510) 984 - 1112



RETAIL RENOVATION
 803 DELAWARE STREET
 BERKELEY, CA 94710

EXISTING SITE PLAN

BUILDING PERMIT

DATE 10/06/22

A1.0





GENERAL NOTES

1. REMOVE ALL (E) LIGHTING AND OUTLETS.
2. REMOVE (E) CEILING FINISH FOR INSTALLATION OF (N) FIRE AND SOUND SEPARATION.

KEY NOTES #

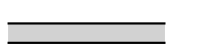
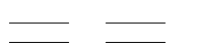
1. REMOVE (E) DOOR
2. REMOVE (E) CONC. STEP
3. REMOVE (E) CABINETS
4. REMOVE (E) PLUMBING FIXTURE
5. WALL DEMO COORDINATED W/ STRUCTURAL
6. SEE STRUCTURAL FOR EXTENT OF DEMOLITION FOR NEW FOOTING.
7. REMOVE PORTION OF EXISTING WALL FOR NEW DOOR.

LEGEND

-  (E) WALL TO REMAIN
-  (E) WALL TO BE REMOVED
-  (E) DOOR TO REMAIN
-  (E) DOOR TO BE REMOVED
-  (E) WINDOW TO REMAIN
-  (E) WINDOW TO BE REMOVED



GUNKEL ARCHITECTURE
1295 59TH STREET
EMERYVILLE CA 94608
GUNKELARCHITECTURE.COM
PHONE: (510) 984 - 1112



RETAIL RENOVATION
803 DELAWARE STREET
BERKELEY, CA 94710

EXISTING & DEMO
FIRST FLOOR
PLAN

BUILDING PERMIT

DATE 10/06/22

A2.0

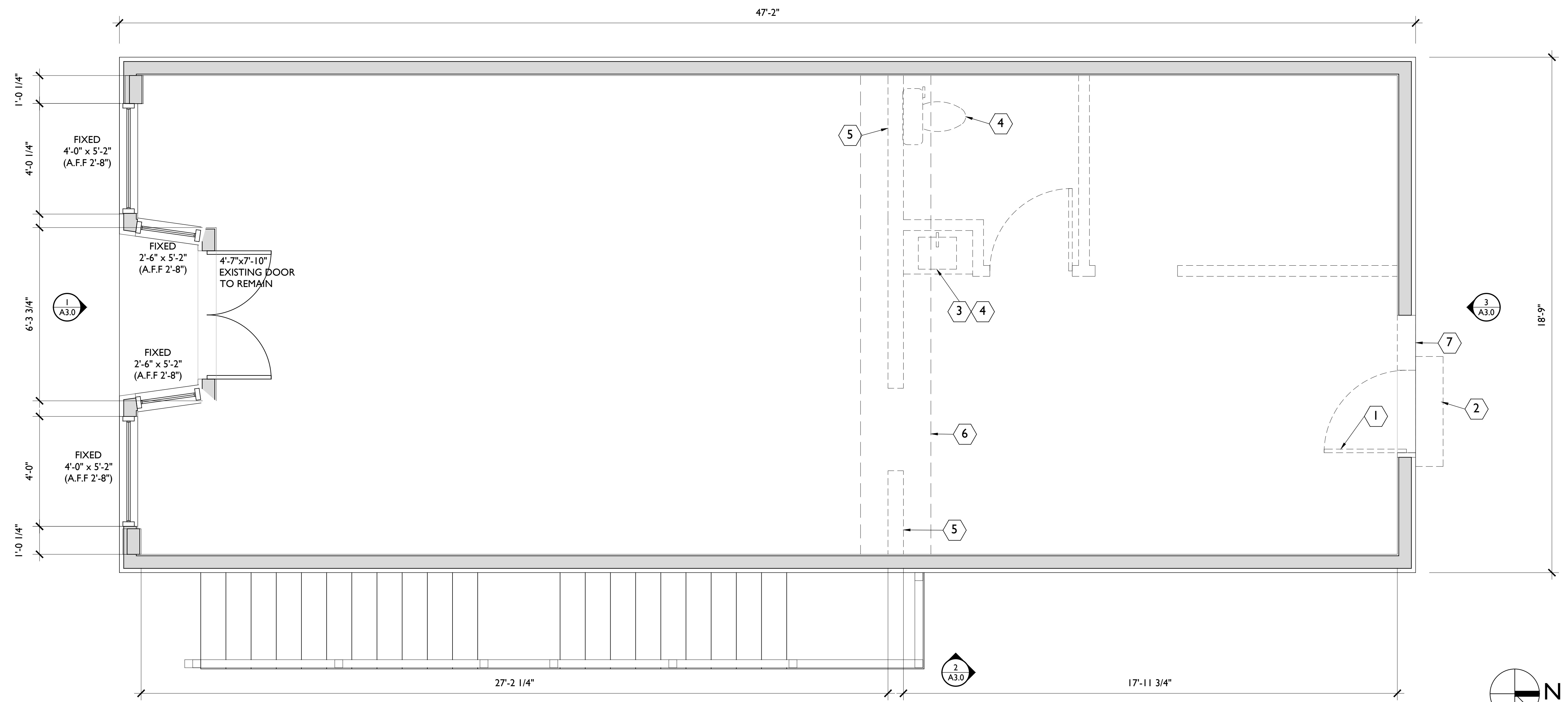

I EXISTING & DEMOLITION FIRST FLOOR PLAN

1/2" = 1'-0"

T-24 LIGHTING & MECHANICAL REQUIREMENTS	KEY NOTES #	ELECTRICAL LEGEND	LEGEND	PROJECT NOTES
<p>ELECTRICAL: ALL NEW ELECTRICAL WORK TO FULLY COMPLY WITH HIGH-EFFICIENCY LIGHTING REQUIREMENTS AS DESCRIBED BELOW BASED ON TITLE 24, PART 6, SUBCHAPTER 7 - SECTION 150.0 MANDATORY FEATURES AND DEVICES. LED LIGHTING MUST BE CERTIFIED TO THE ENERGY COMMISSION BY THE MANUFACTURER TO QUALIFY AS "HIGH EFFICACY"</p> <p>1. SEE GENERAL NOTES FOR SPECIFIC REQUIREMENTS FOR BATHROOM, KITCHEN AND LAUNDRY</p> <p>2. INDOOR LIGHTING: ALL LIGHTS SHALL BE HI-EFFICACY LED AND CONTROLLED BY DIMMERS OR VACANCY SENSORS. NO CONTROLS SHALL BY PASS DIMMER AND VACANCY SENSOR FUNCTION.</p> <p>3. OUTDOOR LIGHTING: ALL EXTERIOR LIGHTS SHALL BE HIGH EFFICACY LED. MANUAL ON AND OFF SWITCH SHALL NOT OVERRIDE AUTOMATIC STRATEGIES: PHOTOCONTROL AND AUTOMATIC TIME SWITCH CONTROL OR ASTRONOMICAL TIME CLOCK OR ENERGY MANAGEMENT SYSTEM.</p> <p>ALL ELECTRIC MECHANICAL SYSTEMS REQUIRED PER BERKELEY MUNICIPAL CODE:</p> <p>UNIT TO RECEIVE:</p> <ul style="list-style-type: none"> - 20 GALLON ELECTRIC HOT WATER HEATER IN LOFT OVER RESTROOM. - EXTERIOR HEAT PUMP CONDENSER, SEE FLOOR PLAN FOR LOCATION. - WALL-PACK FAN COILS AS INDICATED ON RCP. 	<p>SEE GENERAL NOTES FOR CODE REQ'S RELATED TO SPECIFIC ITEMS</p> <p>1. APPLIANCE/PLUMBING FIXTURE PER GENERAL NOTES</p> <p>2. CABINERY/CASEWORK/SHELVING BY OWNER. REQUIRED ACCESSIBLE SALES COUNTER TO HAVE A MINIMUM LENGTH OF 36" AND A HEIGHT BETWEEN 28" AND 34" ABOVE THE FLOOR. REQUIRED KNEE CLEARANCE MINIMUM 27" HIGH AND 19" DEEP (CBC 11B-227.1, 227.3, 904.4)</p> <p>3. CLASS A - I-A-10-B:C MINIMUM RATING PORTABLE FIRE EXTINGUISHER UNDER SINK</p> <p>4. HEAT PUMP CONDENSER, SEE RCP FOR FAN COIL LOCATIONS.</p>	<p>NOTE: ELECTRICAL FIXTURES TO BE SELECTED BY OWNER UNLESS OTHERWISE NOTED</p> <p>DUPLEX/FOURPLEX ELECTRICAL RECEPTACLE:</p> <ul style="list-style-type: none"> - GFI = GROUND FAULT INTERRUPT - MICRO = MICROWAVE - TC = TRASH COMPACTOR - DW = DISHWASHER - REF = REFRIGERATOR - RANGE = RANGE - WASH = WASHER - DRY = DRYER - D = DISPOSER - 220 = DEDICATED 220V RECEPTACLE - EV = ELECTRIC VEHICLE - WP = WEATHER PROOF <p>FLOOR MOUNTED RECEPTACLE</p> <p>▲ TELEPHONE / DATA PORT</p> <p>□ CABLE TELEVISION PORT</p> <p>ALL BRANCH CIRCUITS THAT SUPPLY 120 VOLT, SINGLE PHASE, 15 & 20 AMPERE OUTLETS INSTALLED IN DWELLING UNIT (FAMILY ROOM, DINING ROOM, LIVING ROOM, LIBRARY, DEN, BEDROOM, CLOSET, HALLWAY, SUNROOM, KITCHEN, LAUNDRY OR SIMILAR ROOMS OR AREAS) SHALL BE ARC-FAULT CIRCUIT INTERRUPTER (AFCI) PROTECTED. ALL RECEPTACLES TO BE TAMPER RESISTANT SEC. CEC 406.11</p> <p>PER NEC 210-52(A) LOCATE ELECTRICAL OUTLETS:</p> <ul style="list-style-type: none"> - 12' O.C. MAX AND WITHIN 6' OF THE END OF WALLS. - HEIGHT AT ROOMS & APPLIANCES SHALL BE 14" A.F.F. (CENTER LINE) U.O.N. - HEIGHT AT COUNTERTOPS & LAVATORY/SINKS SHALL BE 44" A.F.F. (CENTER LINE) U.O.N. <p>PER NEC 210-8 PROVIDE GFI PROTECTION AT:</p> <ul style="list-style-type: none"> - ALL RECEPTACLES SERVING KITCHEN COUNTER TOPS - RECEPTACLES WITHIN 6' OF A WET BAR SINK. - AT EACH KITCHEN AND DINING AREA COUNTER SPACE WIDER THAN 12" - ALL RECEPTACLES IN GARAGES AND BASEMENTS OUTDOORS, LAUNDRY, UTILITY ROOMS <p>THE SIZE OF THE SERVICE PANELS FOR THE DWELLING UNITS AS NOT LESS THAN 60 AMPS PER CEC 230.79(D)</p>	<p>EXISTING WALLS</p> <p>NEW WALLS</p> <p>EXISTING WINDOWS</p> <p>EXISTING DOORS</p> <p>NEW DOOR, PER GENERAL NOTES & T24 REQ'S AT EXTERIOR</p>	<p>1. COORDINATE INTERIOR TRIM, FINISHES, + FIXTURES WITH OWNER + ARCHITECT.</p> <p>2. DIMENSIONS ARE TO THE FACE OF STUD, U.O.N.</p> <p>3. VERIFY IN FIELD ALL WINDOW + DOOR OPENING DIMENSIONS PRIOR TO ORDERING</p>



GUNKEL ARCHITECTURE
1295 59TH STREET
EMERYVILLE CA 94608
GUNKELARCHITECTURE.COM
PHONE: (510) 984 - 1112



RETAIL RENOVATION
803 DELAWARE STREET
BERKELEY, CA 94710

IMPROVEMENT FLOOR PLAN

BUILDING PERMIT

DATE 10/06/22

A2.1

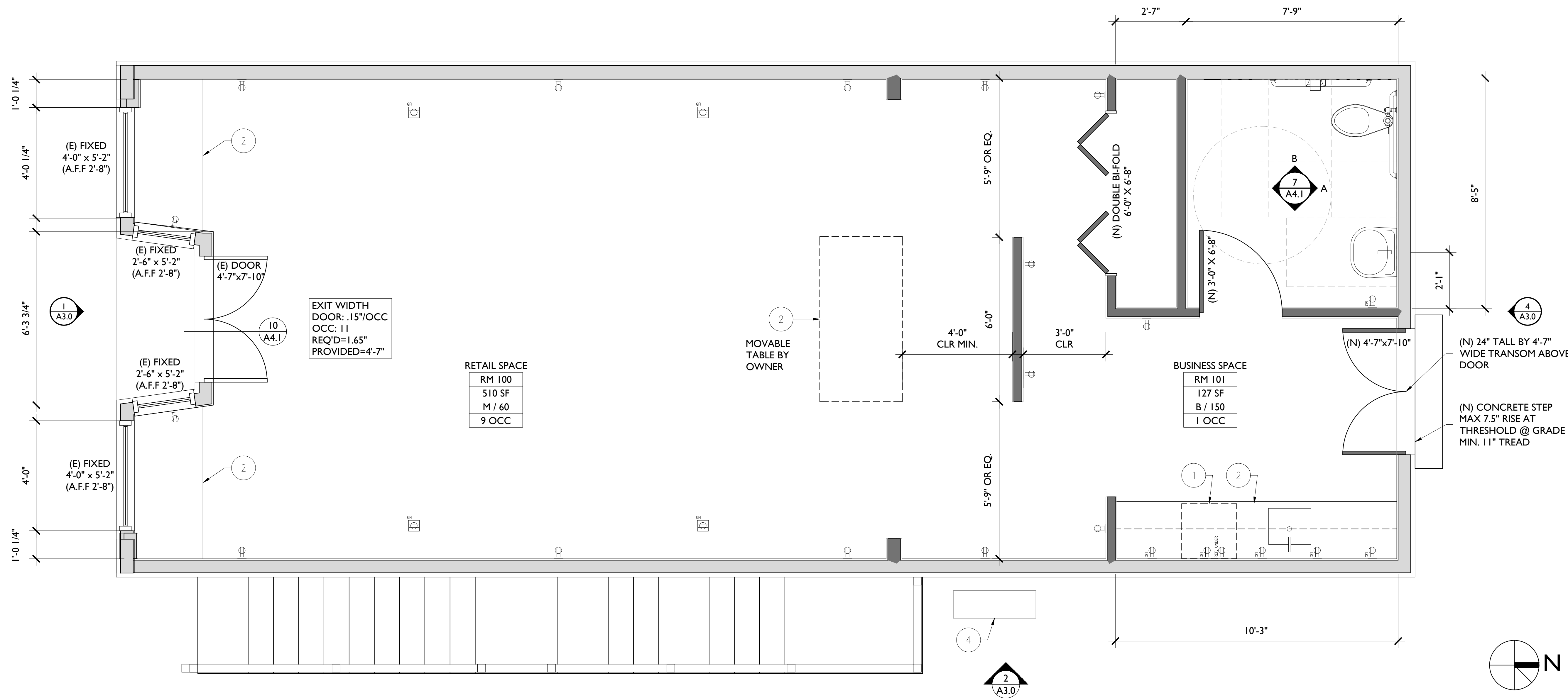

I IMPROVEMENT FIRST FLOOR PLAN

KEYNOTES

- EDGE OF SOFFIT
- DROPPED BEAM, S.S.D., CLADDING TO BE COORD. W/ OWNER
- COORDINATE EXACT LOCATION OF PENDANT LIGHTS W/ OWNER
- 20 GALLON ELECTRIC HOT WATER HEATER ABOVE RESTROOM CEILING IN LOFT. SEE 3/A4.0 FOR STRAPPING
- MINI-SPLIT FAN COIL MOUNTED ON WALL, COORDINATE W/ OWNER.
- NEW FIRE/SOUND RATED CEILING ASSEMBLY, SEE 4/A4.0 FOR DETAIL

GENERAL NOTES

- ALL CEILINGS TO BE FINISHED WITH 5/8" GYP BOARD U.O.N.
- CEILINGS SEPARATING OCCUPANCIES TO BE FINISHED WITH 1 HOUR TYPE 'C' GYP. BD.
- CEILINGS BETWEEN UNITS TO BE CONSTRUCTED WITH RC CHANNELS AND SOUND INSULATION TO ACHIEVE A MIN. STC RATING OF 50, AND MIN. I.I.C. RATING OF 45.
- SMOKE ALARMS LISTED IN ACCORDANCE WITH UL 217 AND STATE FIRE MARSHAL APPROVE FOR SMOKE ALARM. [CFC §907.2.10]
- SMOKE ALARMS MUST BE INTERCONNECTED IN ACCORDANCE WITH CFC §907.2.10.5.
- SMOKE ALARMS INSTALLED LESS THAN 20-FEET HORIZONTAL DISTANCE FROM A PERMANENTLY INSTALLED COOKING APPLIANCE MUST BE AN IONIZATION SMOKE ALARM WITH AN ALARM-SILENCING SWITCH, OR PHOTOELECTRIC SMOKE ALARM. [CFC §907.2.10.8 (NFPA 72 §29.8.3.4 ITEM 4)]
- SMOKE ALARMS MUST BE INSTALLED MIN 3-FOOT HORIZONTAL DISTANCE FROM THE DOOR OR OPENING OF A BATHROOM THAT CONTAINS A BATHTUB OR SHOWER. [CFC §907.2.10.8 (NFPA 72 §29.8.3.4 ITEM 5)]
- CARBON MONOXIDE ALARM MUST BE LISTED IN ACCORDANCE WITH UL 2034. [CFC §915.4.2]
- CO ALARMS MUST BE INTERCONNECTED IN ACCORDANCE WITH CFC §915.4.4.
- SMOKE AND CO ALARMS SHALL RECEIVE THEIR PRIMARY POWER FROM THE BUILDING'S ELECTRICAL SYSTEM, AND SHALL HAVE A BATTERY BACKUP POWER SUPPLY [CFC §907.2.10.6 AND CFC §915.4.1].

T-24 LIGHTING REQ'MNTS

ELECTRICAL:
ALL NEW ELECTRICAL WORK TO FULLY COMPLY WITH HIGH-EFFICIENCY LIGHTING REQUIREMENTS AS DESCRIBED BELOW BASED ON TITLE 24, PART 6, SUBCHAPTER 7 - SECTION 150.0 MANDATORY FEATURES AND DEVICES, SUBSECTION K RESIDENTIAL LIGHTING. LED AND FLUORESCENT LIGHTING MUST BE CERTIFIED TO THE ENERGY COMMISSION BY THE MANUFACTURER TO QUALIFY AS "HIGH EFFICACY"

- SEE GENERAL NOTES FOR SPECIFIC REQUIREMENTS FOR BATHROOM, KITCHEN, AND LAUNDRY
- OTHER ROOMS: ALL LIGHTS SHALL BE LED. DIMMERS OR VACANCY SENSORS SHALL CONTROL ALL LUMINAIRES REQUIRED TO HAVE LIGHT SOURCES COMPLIANT WITH REFERENCE JOINT APPENDIX JA8 PER CEC 150.0(k) (CLOSETS <70 SF AND HALLWAYS ARE EXEMPT)
- OUTDOOR LIGHTING: ALL EXTERIOR LIGHTS SHALL BE LED. MANUAL ON AND OFF SWITCH SHALL NOT OVERRIDE AUTOMATIC STRATEGIES: PHOTOCONTROL AND AUTOMATIC TIME SWITCH CONTROL OR ASTRONOMICAL TIME CLOCK OR ENERGY MANAGEMENT SYSTEM.

ELECTRICAL LEGEND AND NOTES

NOTE: ELECTRICAL FIXTURES TO BE SELECTED BY OWNER UNLESS OTHERWISE NOTED

LIGHT SWITCH TYPE:
- D = DIMMER CONTROL
- 3 = 3-WAY
- S = OCCUPANT SENSOR
- DASHED LINE INDICATES CIRCUIT

LIGHT FIXTURE TYPE:
- P/M = PHOTOCONTROL/MOTION SENSOR CONTROLLED
- "A" = DAMP RATED
- F = FLUORESCENT W/ ELEC BALLAST
VS = VACANCY SENSOR
MS = MOTION SENSOR

WALL MOUNTED SCONCE
WALL MOUNTED LIGHT

LED RECESSED LIGHTS COORD. W/ OWNER & ARCH.
CONCEALED LINEAR STRIP LIGHT (12"=13W; 18"=15W; 24"=20W; 48"=32W U.O.N.)
SURFACE MOUNTED STRIP LIGHT (12"=13W; 18"=15W; 24"=20W; 48"=32W U.O.N.)
PENDANT OR FLUSH MOUNT LIGHT

LINE VOLTAGE TRACK WITH LOW VOLTAGE HEADS MR-16 GIMBAL RING TYPE
LINE VOLTAGE FLUSH MOUNT LIGHT (24"X48" 2-LAMP U.O.N.)
LED BAR WITH MOTION SENSOR
SMOKE ALARM (PHOTOELECTRIC)
CARBON MONOXIDE ALARM
EXHAUST FAN
- C = COMBINED LIGHT AND FAN
WALL MECHANICAL AIR REGISTER
CEILING MECHANICAL AIR REGISTER
COLD AIR RETURN
WOOD SOFFIT TO MATCH WOOD SIDING
STUCCO EXTERIOR SOFFIT
LEVEL SOFFITED GYP. BD. CEILING

RECESSED LIGHT FIXTURES IN INSULATED CEILINGS SHALL BE APPROVED, LISTED, ZERO-CLEARANCE INSULATION COVER (IC) TYPE, AIR-TIGHT (ASTM E283) AND SEALED WITH A GASKET OR CAULKED BETWEEN HOUSING AND CEILING

LOCATE ELECTRICAL WALL MOUNTED LIGHT SWITCH:
- HEIGHT AT ROOMS & APPLIANCES SHALL BE 44" A.F.F. (CENTER LINE) U.O.N.

LIGHTING SCHEDULE

TAG	DESCRIPTION	TYPE
R1	SINGLE RECESSED CAN	LED
R2	DOUBLE RECESSED CAN	LED
R3	SURFACE 'RECESSED' LIGHT	LED
S1	DISPLAY SCONCE	LED
S2	VANITY SCONCE	LED
P1	PENDANT - COUNTER	LED
P2	PENDANT - WINDOW	LED
E1	EXTERIOR SCONCE	LED
E2	EXTERIOR SCONCE	LED
L1	LED TAPE LIGHT	LED

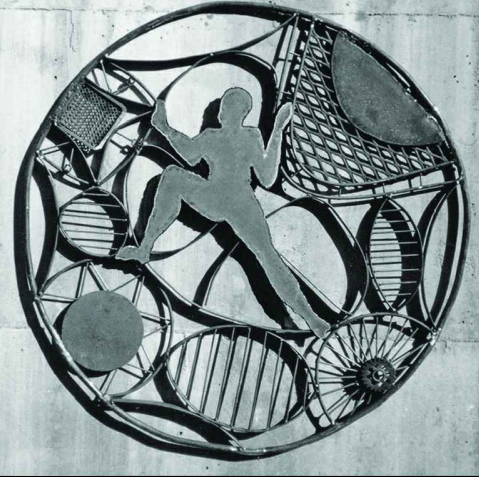

GUNKEL ARCHITECTURE
1295 59TH STREET
EMERYVILLE CA 94608
GUNKELARCHITECTURE.COM
PHONE: (510) 984 - 1112



RETAIL RENOVATION
803 DELAWARE STREET
BERKELEY, CA 94710

IMPROVEMENT
RCP

BUILDING PERMIT

DATE 10/06/22

A2.2

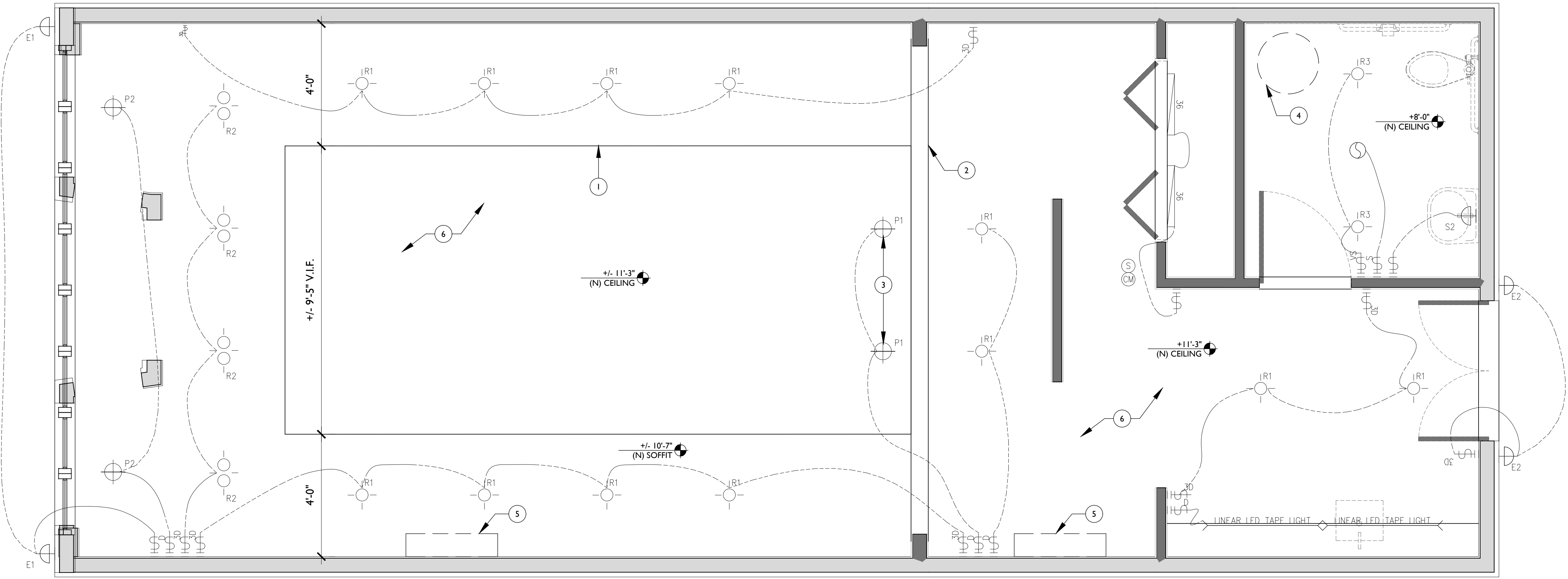

I IMPROVEMENT REFLECTED CEILING PLAN

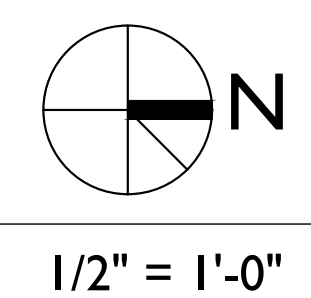

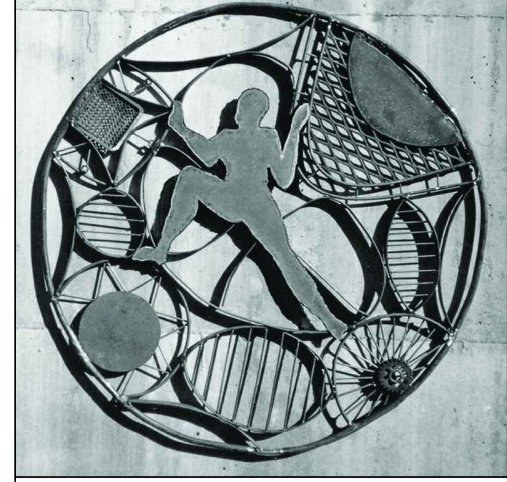

GUNKEL ARCHITECTURE
1295 59TH STREET
EMERYVILLE CA 94608
GUNKELARCHITECTURE.COM
PHONE: (510) 984 - 1112



RETAIL RENOVATION
803 DELAWARE STREET
BERKELEY, CA 94710

EXISTING & IMPROVEMENT ELEVATIONS

BUILDING PERMIT

DATE 10/06/22



2 EXISTING ELEVATION - EAST - NO CHANGE

SCALE
1/4" = 1'-0"



4 IMPROVEMENT ELEVATION - NORTH

SCALE
1/4" = 1'-0"

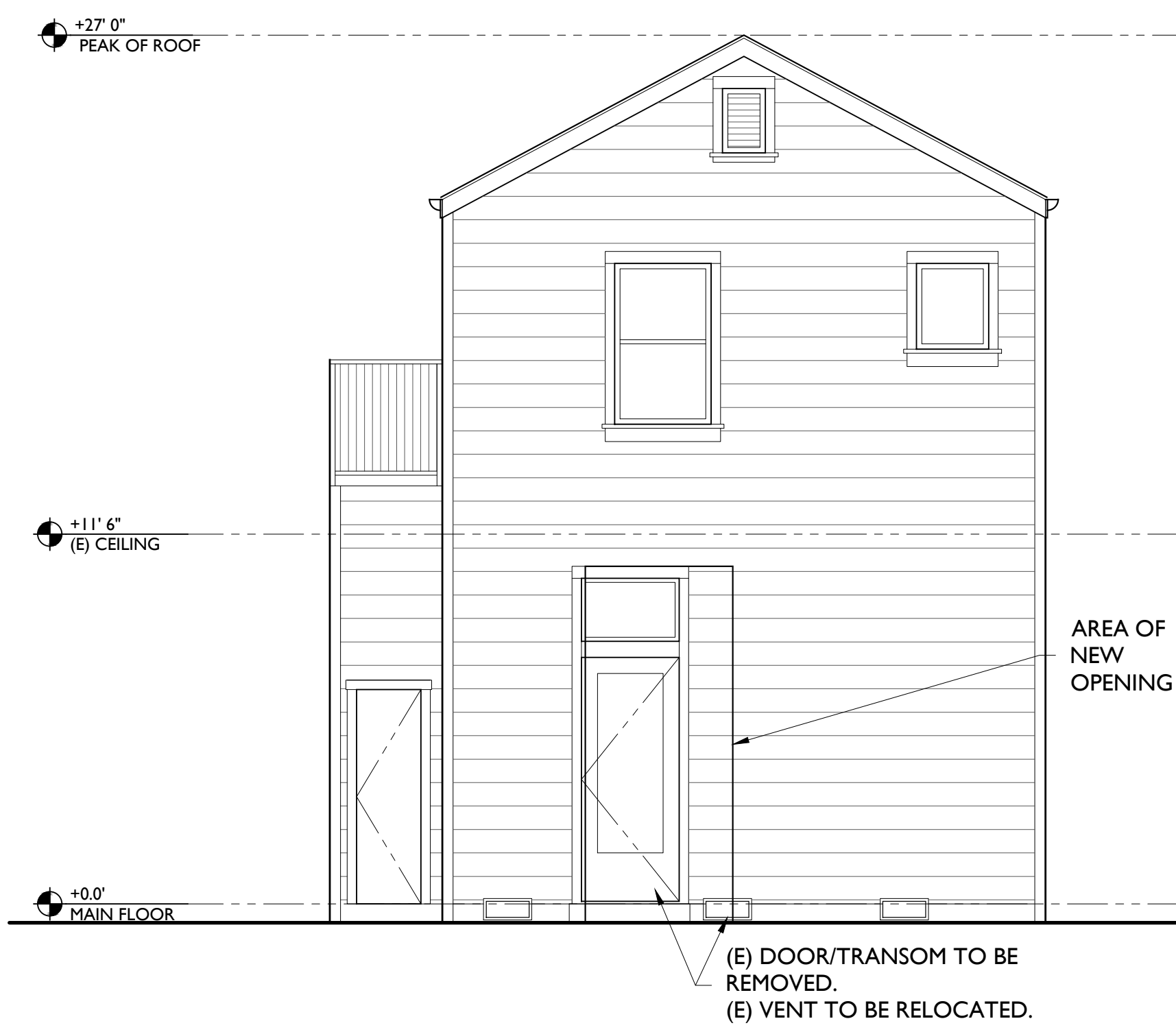

3 EXISTING ELEVATION - NORTH

SCALE
1/4" = 1'-0"

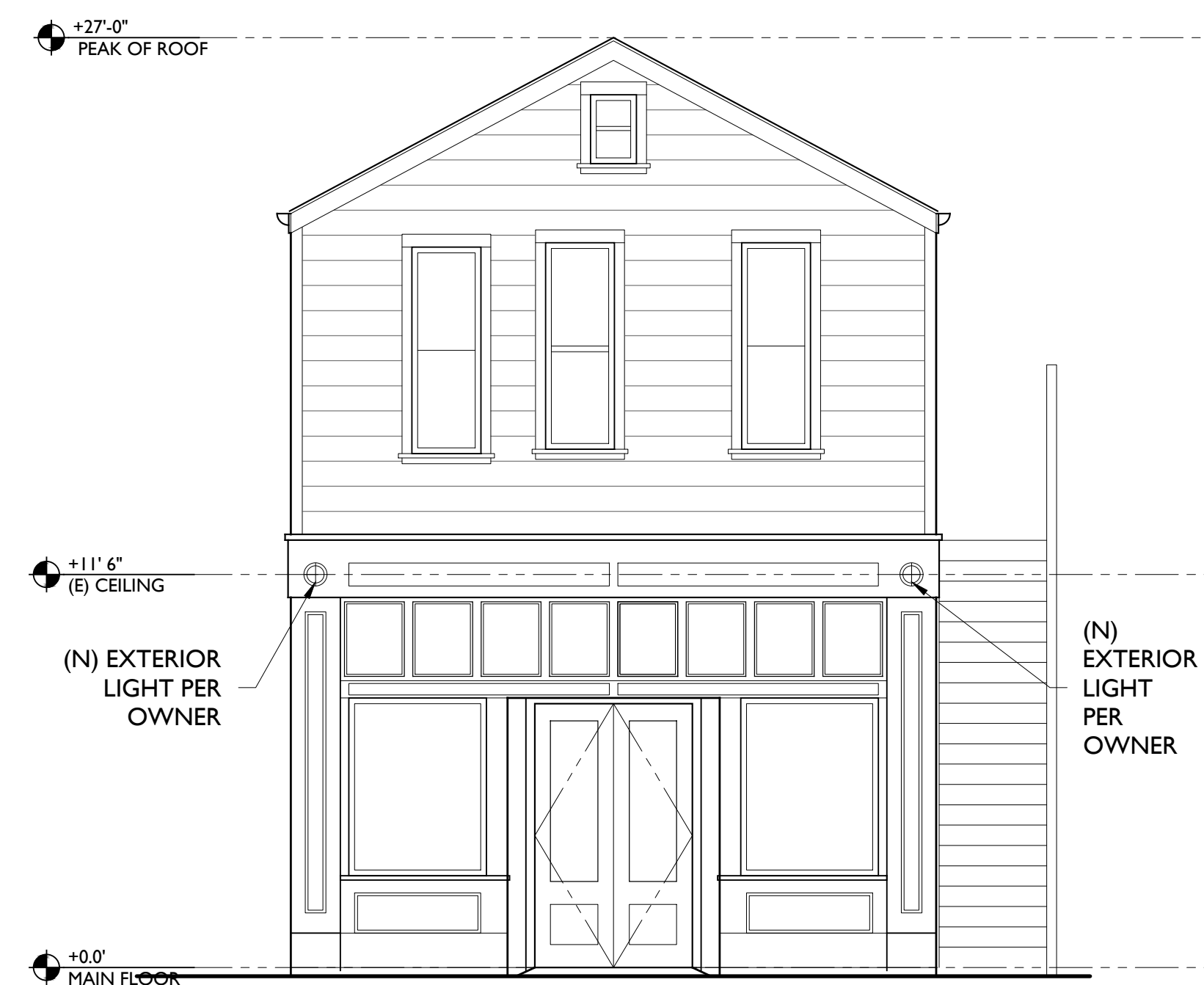

1 EXISTING ELEVATION - SOUTH - NO CHANGE

SCALE
1/4" = 1'-0"

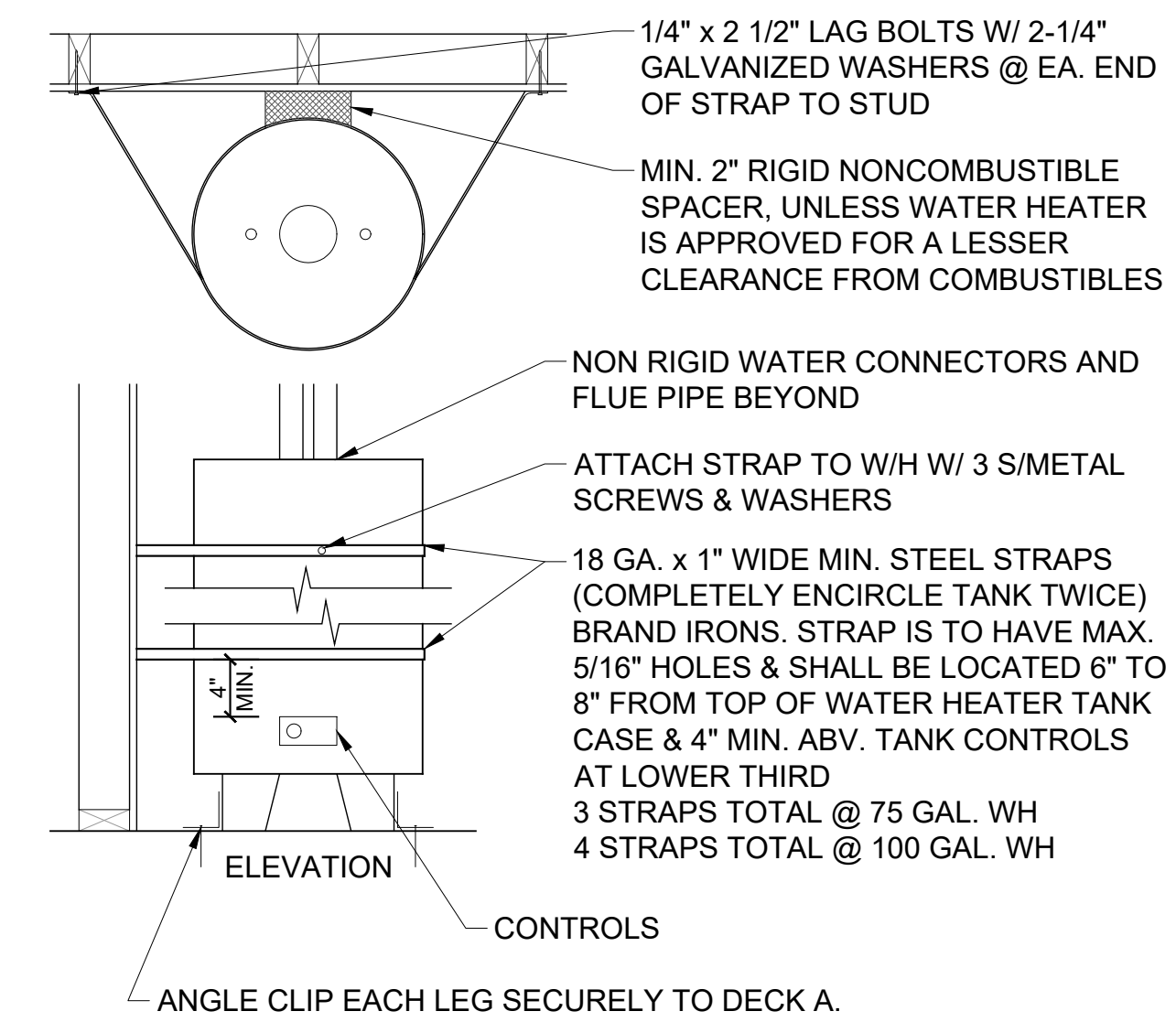

3 WATER HEATER ANCHORAGE

SCALE
1" = 1'-0"

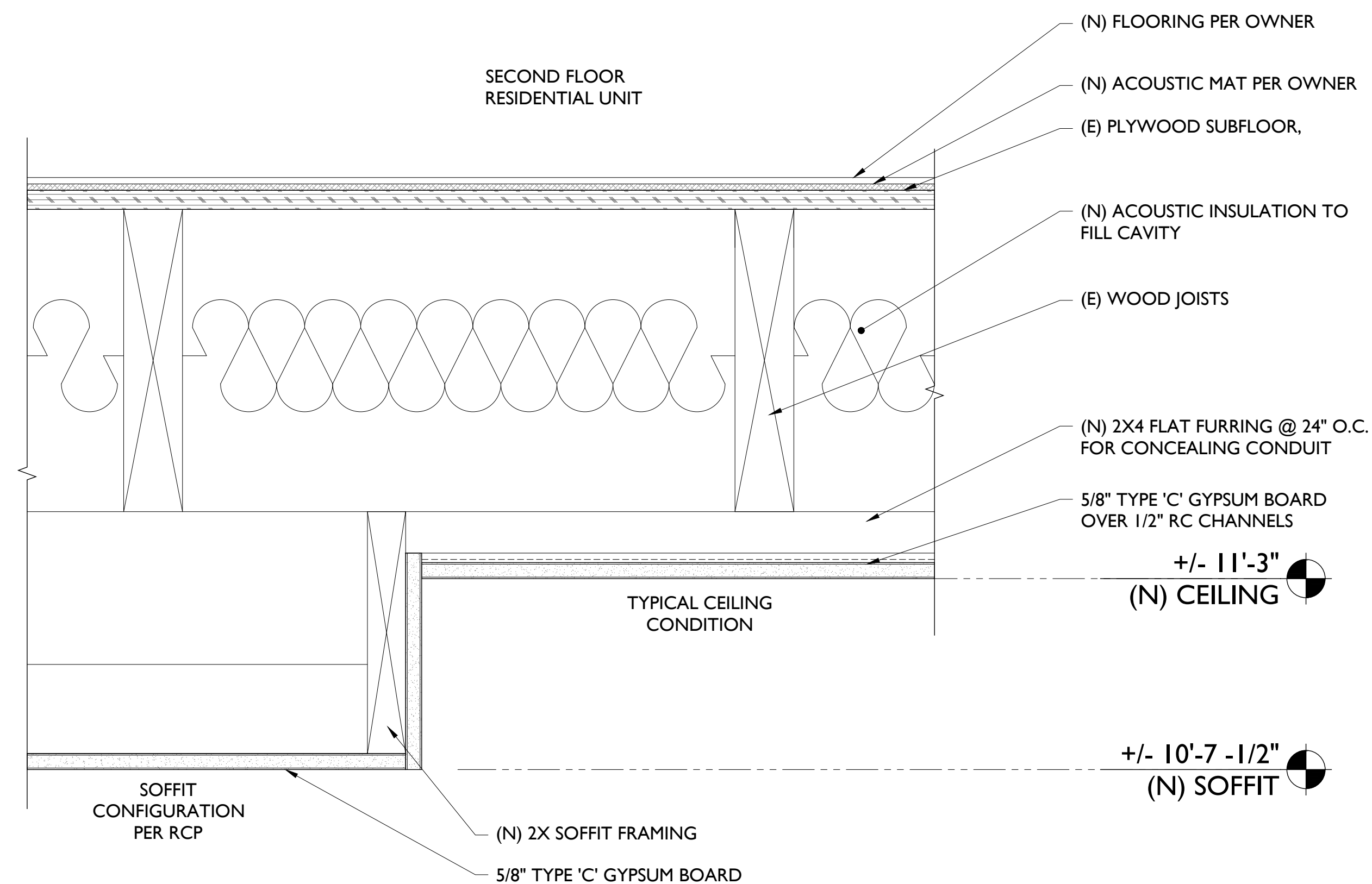

4 1 HR RATED CEILING AND SOFFIT ASSEMBLY - SECTION

SCALE
3" = 1'-0"



GUNKEL ARCHITECTURE
1295 59TH STREET
EMERYVILLE CA 94608
GUNKELARCHITECTURE.COM
PHONE: (510) 984 - 1112



RETAIL RENOVATION
803 DELAWARE STREET
BERKELEY, CA 94710

DETAILS

BUILDING PERMIT

DATE 10/06/22



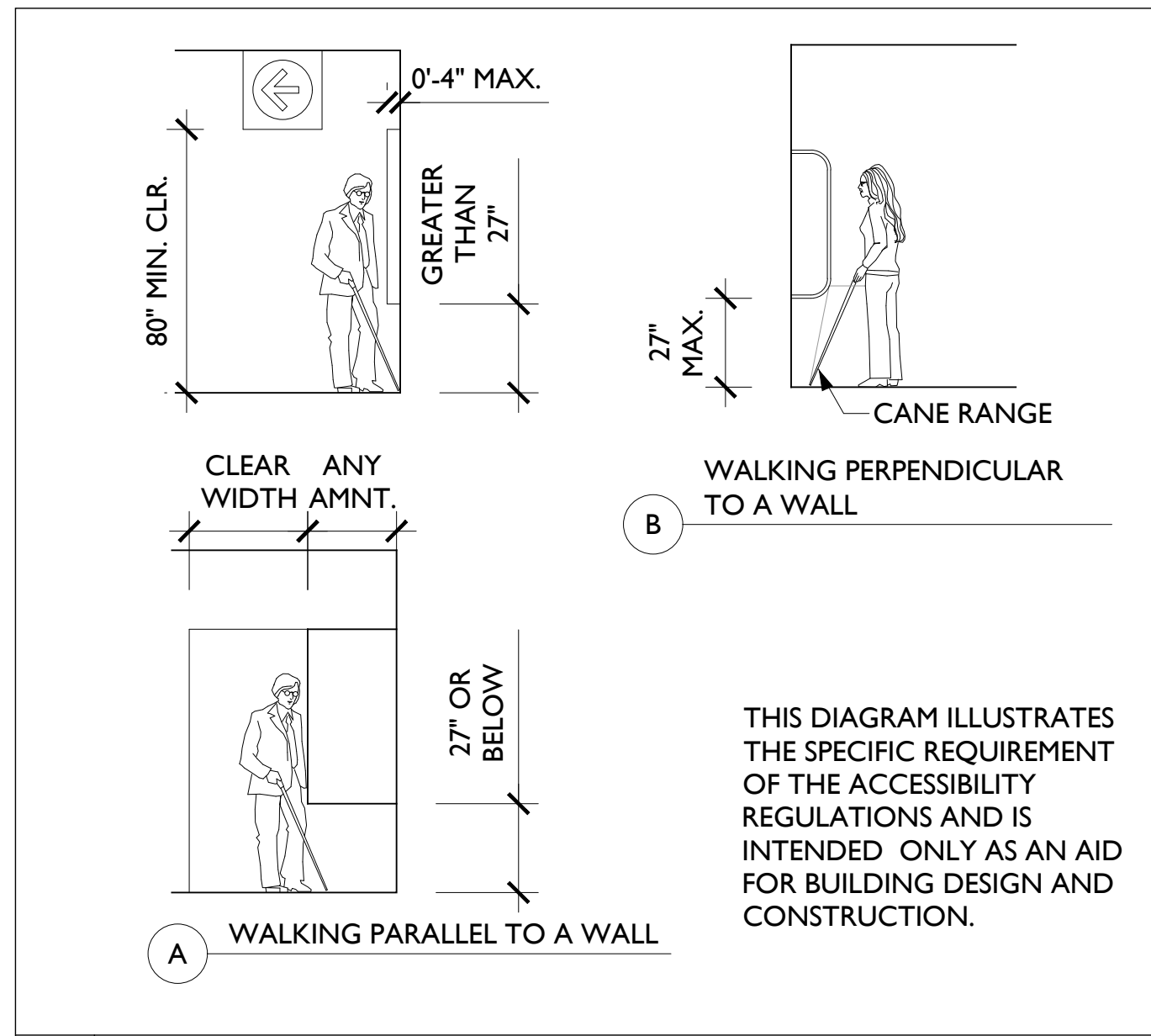

6 PROTRUDING OBJECTS SCALE 1/4" = 1'-0"

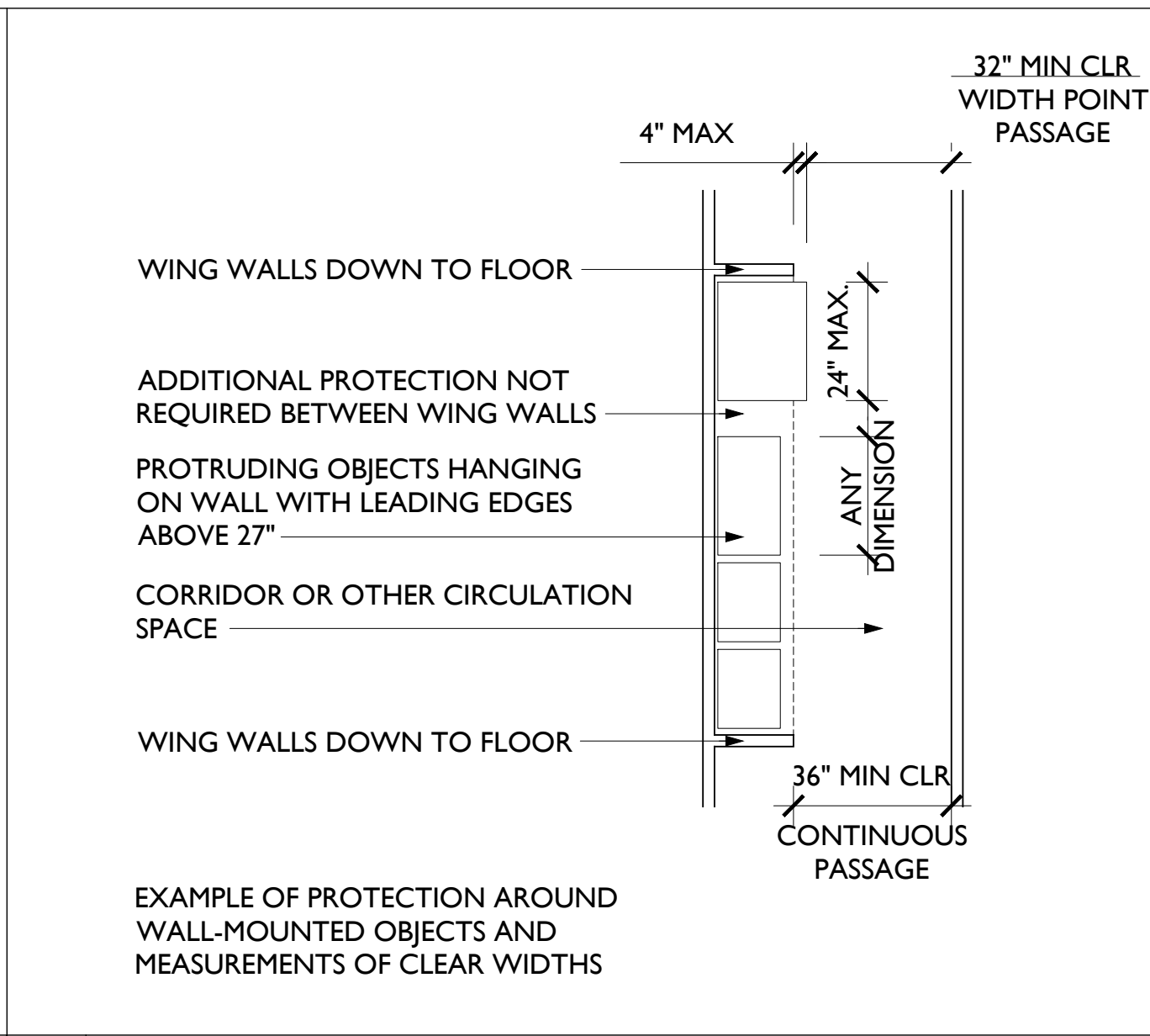

9 WALL MOUNTED OBJECTS SCALE 1/4" = 1'-0"

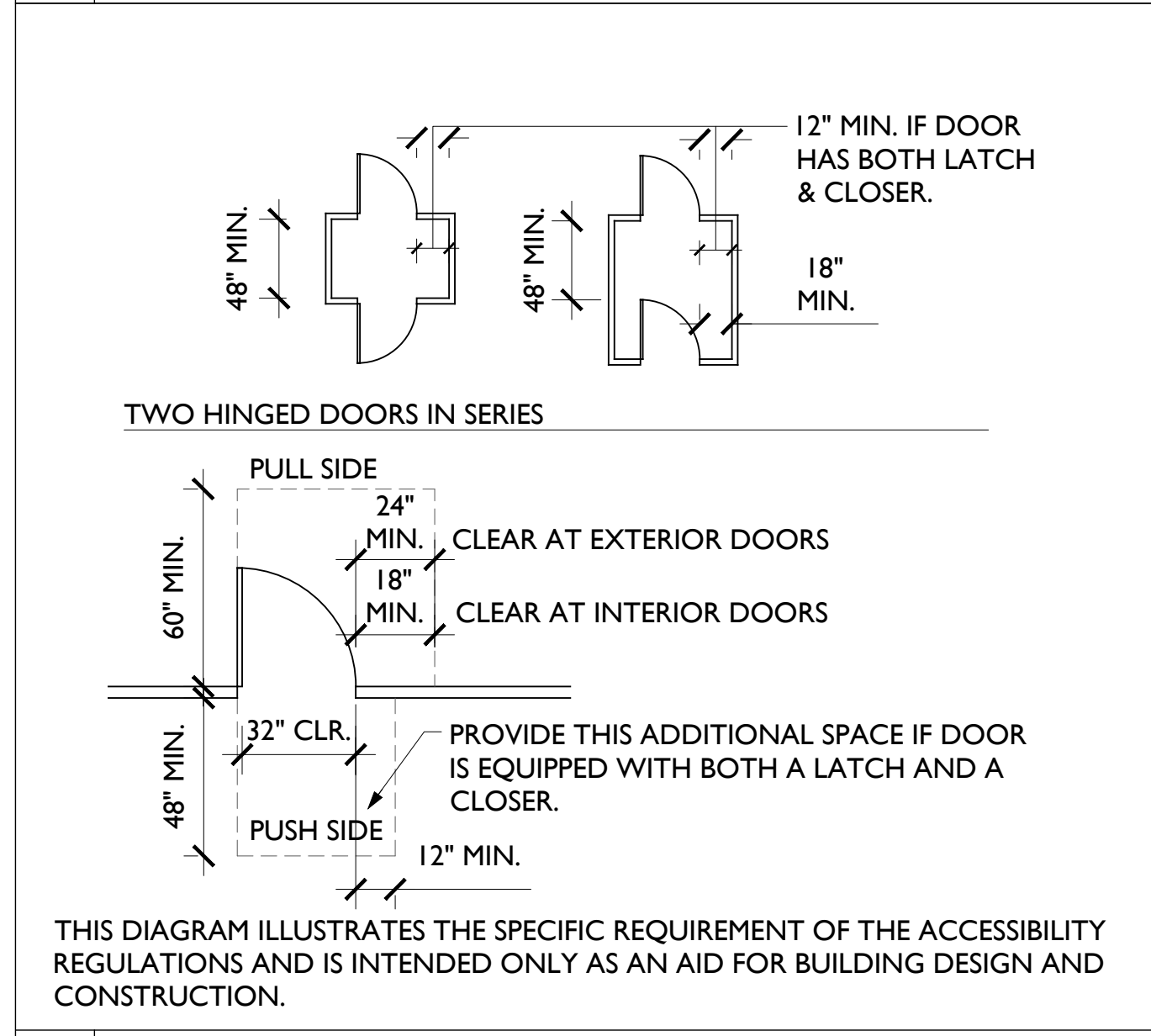

3 FRONT APPROACH DOOR CLEARANCES SCALE 1/4" = 1'-0"

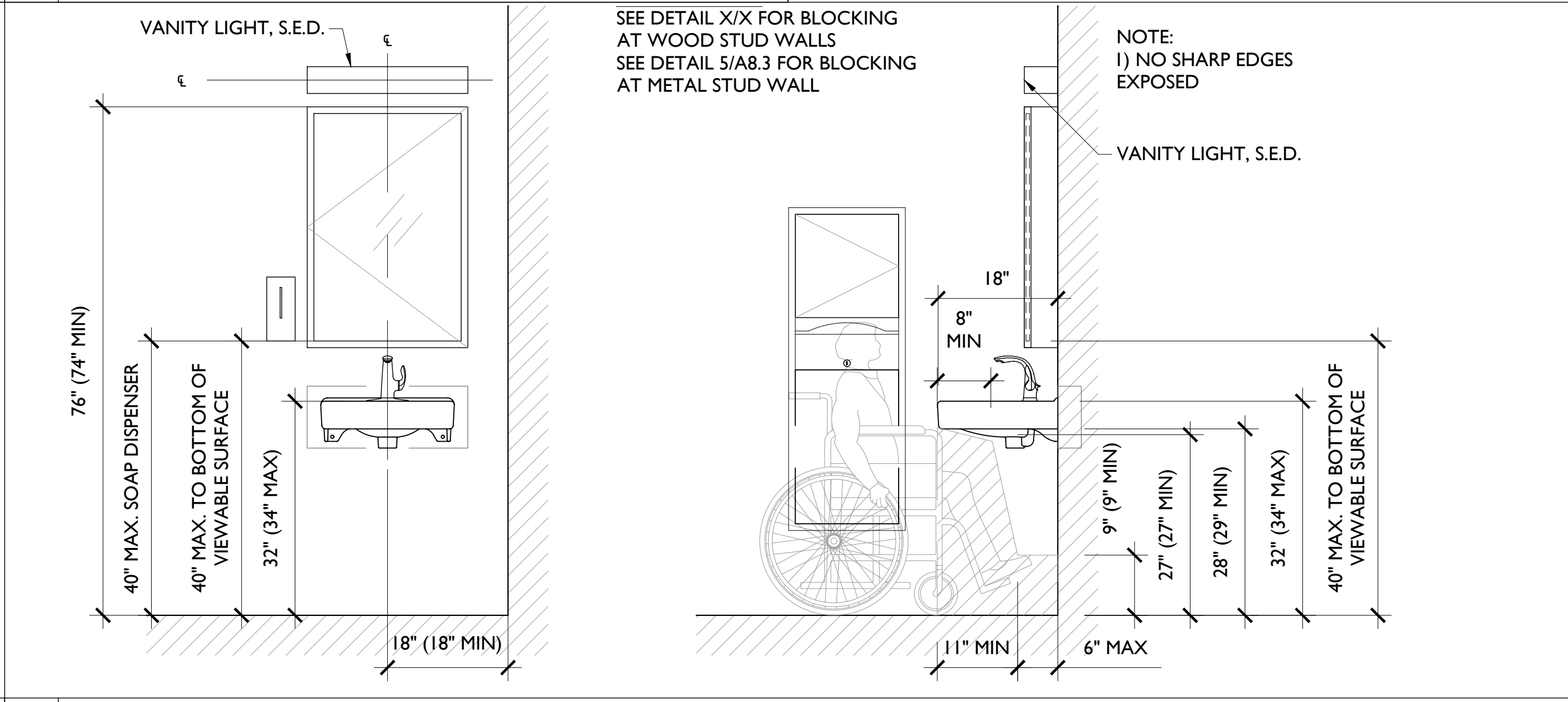

8 LAVATORY- ACCESSIBILITY REQ'S AT COMMON AREAS SCALE 3/4" = 1'-0"

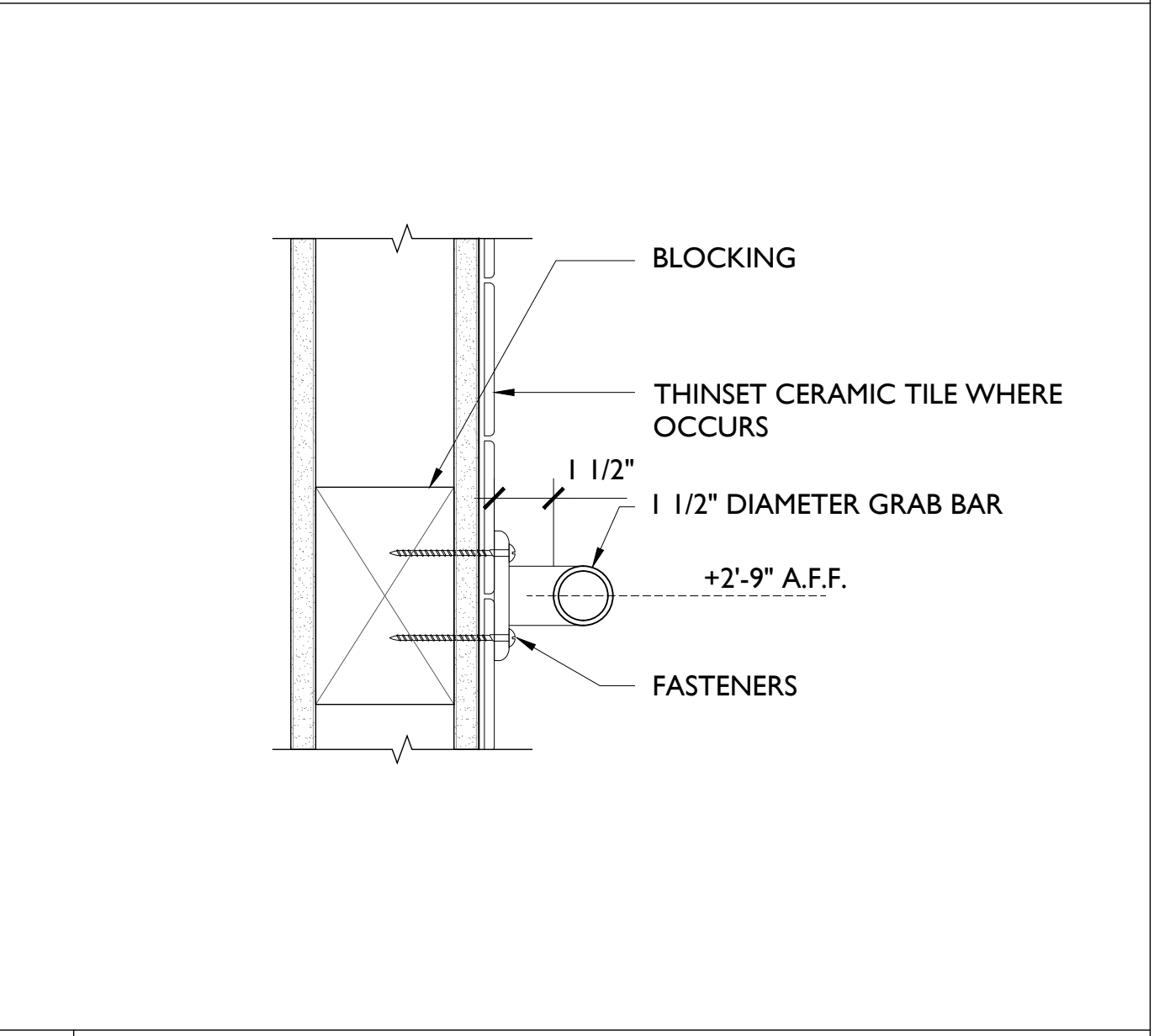

2 SECTION THROUGH GRAB BAR SCALE 3" = 1'-0"

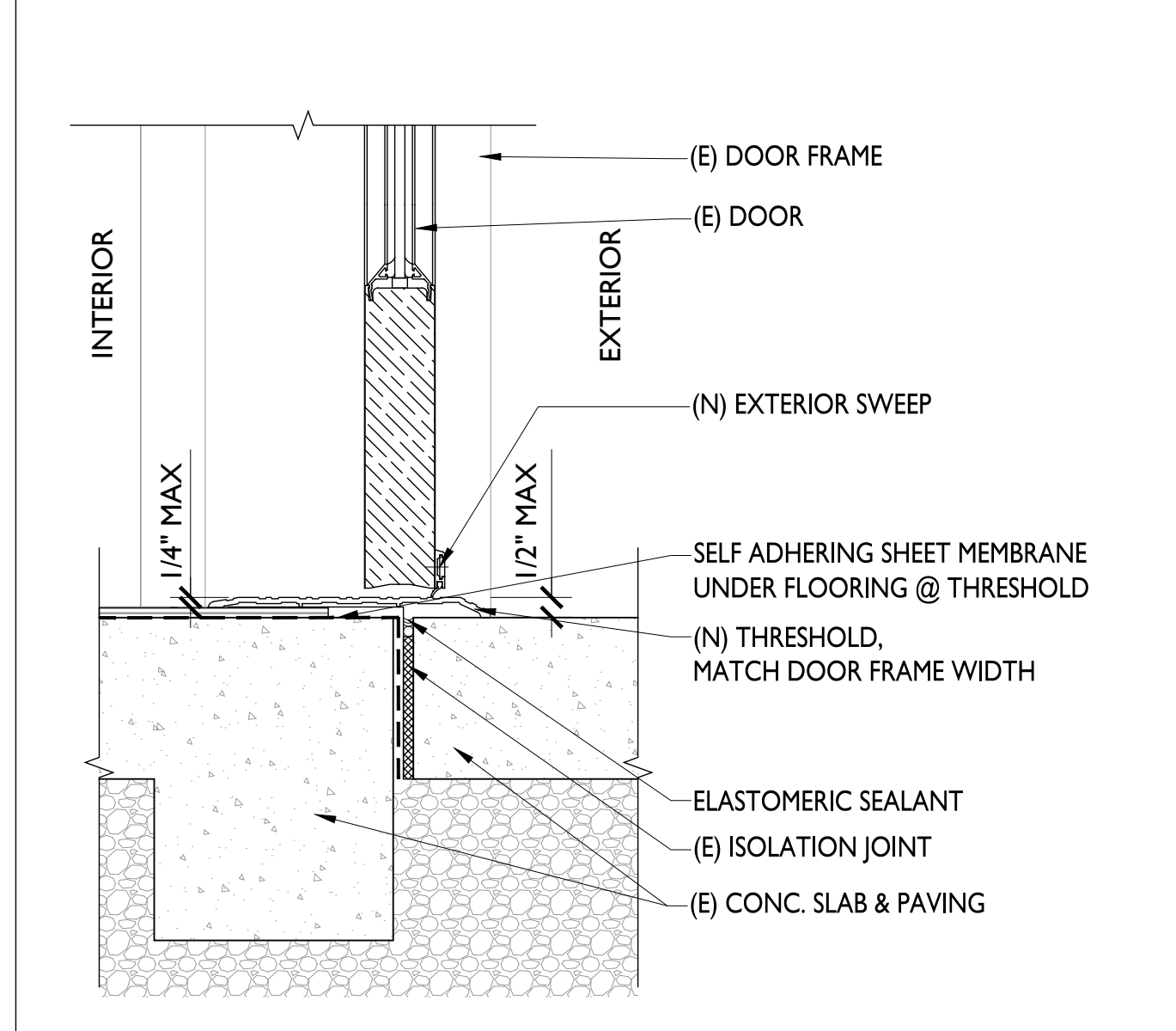

10 EXTERIOR DOOR - THRESHOLD SCALE 3" = 1'-0"

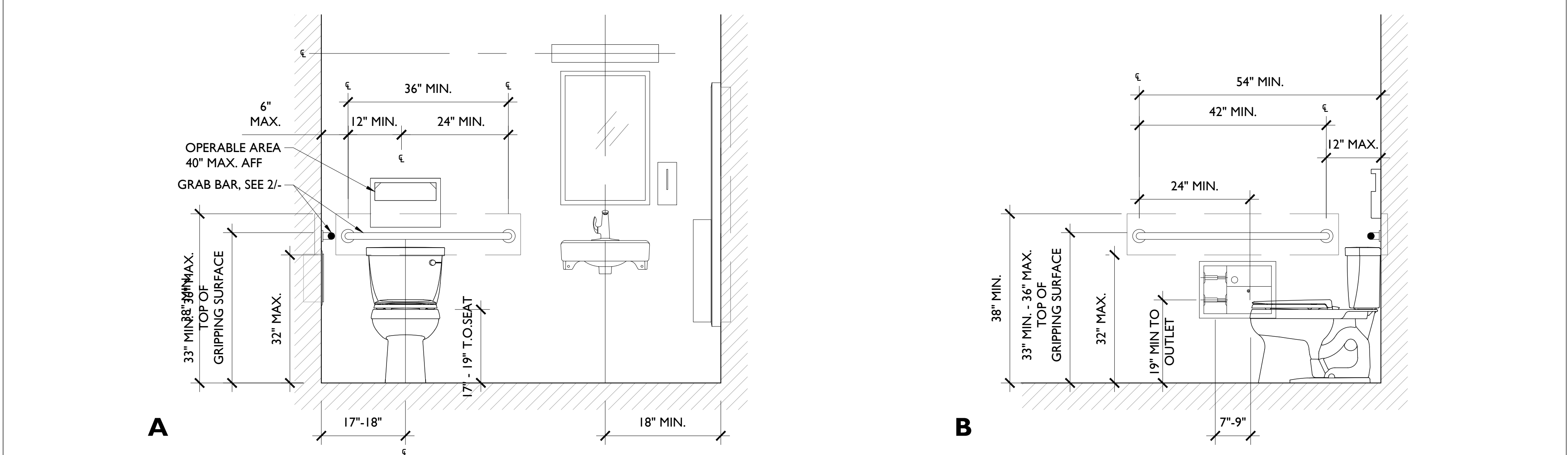

7 ACCESSIBLE BATHROOM - ELEVATION SCALE 3/4" = 1'-0"

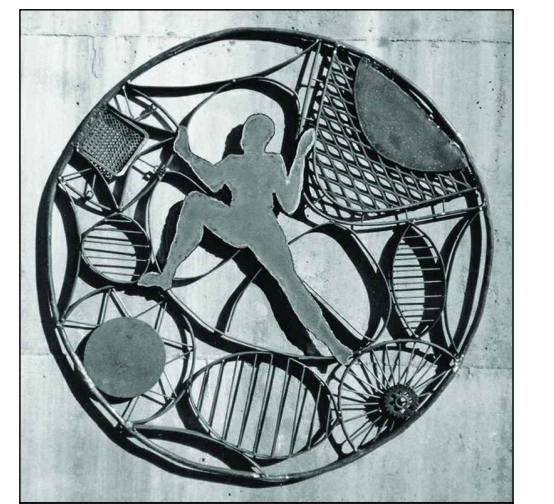

GUNKEL ARCHITECTURE
1295 59TH STREET
EMERYVILLE CA 94608
GUNKELARCHITECTURE.COM
PHONE: (510) 984 - 1112



RETAIL RENOVATION
803 DELAWARE STREET
BERKELEY, CA 94710

ACCESSIBILITY DETAILS

BUILDING PERMIT

DATE 10/06/22

A4.1

FASTENING SCHEDULE TABLE R602.3(1)

TABLE R602.3(1) FASTENING SCHEDULE			
ITEM	DESCRIPTION OF BUILDING ELEMENTS	NUMBER AND TYPE OF FASTENER**	SPACING AND LOCATION
Roof			
1	Blocking between ceiling joists or rafters to top plate	4-8d box (2 1/2" x 0.113"); or 3-8d common (2 1/2" x 0.131"); or 3-10d box (3" x 0.128"); or 3-3" x 0.131" nails	Toe nail
2	Ceiling joists to top plate	4-8d box (2 1/2" x 0.113"); or 3-8d common (2 1/2" x 0.131"); or 3-10d box (3" x 0.128"); or 3-3" x 0.131" nails	Per joist, toe nail
3	Ceiling joist not attached to parallel rafter, laps over partitions [see Sections R802.3.1, R802.3.2 and Table R802.5.1(9)]	4-10d box (3" x 0.128"); or 3-10d common (3" x 0.148"); or 4-3" x 0.131" nails	Face nail
4	Ceiling joist attached to parallel rafter (heel joint) [see Sections R802.3.1 and R802.3.2 and Table R802.5.1(9)]	Table R802.5.1(9)	Face nail
5	Collar tie to rafter, face nail or 1 1/2" x 20 ga. ridge strap to rafter	4-10d box (3" x 0.128"); or 3-10d common (3" x 0.148"); or 4-3" x 0.131" nails	Face nail each rafter
6	Rafter or roof truss to plate	3-16d box nails (3/2" x 0.135"); or 3-10d common nails (3" x 0.148"); or 4-10d box (3" x 0.128"); or 4-3" x 0.131" nails	2 toe nails on one side and 1 toe nail on opposite side of each rafter or truss
7	Roof rafters to ridge, valley or hip rafters or roof rafter to minimum 2" ridge beam	4-16d (3/2" x 0.135"); or 3-10d common (3" x 0.148"); or 4-10d box (3" x 0.128"); or 4-3" x 0.131" nails	Toe nail
Wall			
8	Stud to stud (not at braced wall panels)	16d common (3/2" x 0.162"); 10d box (3" x 0.128"); or 3" x 0.131" nails	24" o.c. face nail 16" o.c. face nail
9	Stud to stud and abutting studs at intersecting wall corners (at braced wall panels)	16d common (3/2" x 0.162"); or 3" x 0.131" nails	12" o.c. face nail
10	Built-up header (2" to 2" header with 1/2" spacer)	16d common (3/2" x 0.162"); 16d box (3/2" x 0.135")	16" o.c. each edge face nail 12" o.c. each edge face nail
11	Continuous header to stud	5-8d box (2 1/2" x 0.113"); or 4-8d common (2 1/2" x 0.131"); or 4-10d box (3" x 0.128")	Toe nail
12	Top plate to top plate	16d common (3/2" x 0.162"); 10d box (3" x 0.128"); or 3" x 0.131" nails	16" o.c. face nail 12" o.c. face nail
13	Double top plate splice for SDCs A-D ₂ with seismic braced wall line spacing < 25'	8-16d common (3/2" x 0.162"); or 12-16d box (3/2" x 0.135"); or 12-10d box (3" x 0.128"); or 12-3" x 0.131" nails	Face nail on each side of end joint (minimum 24" lap-splice length each side of end joint)
	Double top plate splice SDCs D ₃ , D ₁ , or D ₂ and braced wall line spacing ≥ 25'	12-16d (3/2" x 0.135")	

TABLE R602.3(1)—continued FASTENING SCHEDULE			
ITEM	DESCRIPTION OF BUILDING ELEMENTS	NUMBER AND TYPE OF FASTENER**	SPACING AND LOCATION
14	Bottom plate to joist, rim joist, band joist or blocking (not at braced wall panels)	16d common (3/2" x 0.162"); 16d box (3/2" x 0.135"); or 3" x 0.131" nails	16" o.c. face nail
15	Bottom plate to joist, rim joist, band joist or blocking (at braced wall panel)	3-16d box (3/2" x 0.135"); or 2-16d common (3" x 0.162"); or 4-3" x 0.131" nails	3 each 16" o.c. face nail 2 each 16" o.c. face nail 4 each 16" o.c. face nail
16	Top or bottom plate to stud	4-8d box (2 1/2" x 0.113"); or 3-16d box (3/2" x 0.135"); or 4-8d common (2 1/2" x 0.131"); or 4-10d box (3" x 0.128"); or 4-3" x 0.131" nails	Toe nail
		3-16d box (3/2" x 0.135"); or 2-16d common (3" x 0.162"); or 3-10d box (3" x 0.128"); or 3-3" x 0.131" nails	End nail
17	Top plates, laps at corners and intersections	3-10d box (3" x 0.128"); or 2-16d common (3" x 0.162"); or 3-3" x 0.131" nails	Face nail
18	1" brace to each stud and plate	3-8d box (2 1/2" x 0.113"); or 2-8d common (2 1/2" x 0.131"); or 2-10d box (3" x 0.128"); or 2 staples 1 1/2"	Face nail
19	1" x 6" sheathing to each bearing	3-8d box (2 1/2" x 0.113"); or 2-8d common (2 1/2" x 0.131"); or 2-10d box (3" x 0.128"); or 2 staples, 1" crown, 16 ga., 1 1/2" long	Face nail
20	1" x 8" and wider sheathing to each bearing	Wider than 1" x 8" 4-8d box (2 1/2" x 0.113"); or 3-8d common (2 1/2" x 0.131"); or 3-10d box (3" x 0.128"); or 4 staples, 1" crown, 16 ga., 1 1/2" long	Face nail
Floor			
	Joist to sill, top plate or girder	4-8d box (2 1/2" x 0.113"); or 3-8d common (2 1/2" x 0.131"); or 3-10d box (3" x 0.128"); or 3-3" x 0.131" nails	Toe nail
22	Rim joist, band joist or blocking to sill or top plate (roof applications also)	8d box (2 1/2" x 0.113"); or 8d common (2 1/2" x 0.131"); or 10d box (3" x 0.128"); or 3" x 0.131" nails	4" o.c. toe nail 6" o.c. toe nail
23	1" x 6" subfloor or less to each joist	3-8d box (2 1/2" x 0.113"); or 2-8d common (2 1/2" x 0.131"); or 3-10d box (3" x 0.128"); or 2 staples, 1" crown, 16 ga., 1 1/2" long	Face nail

NOTES:

- HEADER: USE 4X12 HEADER FOR ALL 1ST FLOOR DOORS AND OPENING U.O.N. AND 4X10 HEADER FOR ALL 2ND FLOOR DOORS AND OPENING U.O.N.
- HOLD DOWN : SEE SHEAR WALL SCHEDULE
- TIE DOWN : SEE SHEAR WALL SCHEDULE (TS)
- 4X4 POST CONT. TO FND U.O.N.
- 4X4 POST U.O.N.
- ⊠ 4X4 KING POST U.O.N.

ABBREVIATIONS

- | | | |
|-----------------|-------------------|---------------------|
| (E) EXISTING | FBM: FLOOR BEAM | C.J.: CEILING JOIST |
| (N) NEW | CBM: CEILING BEAM | R.R.: ROOF RAFTER |
| ⊥ CENTER LINE | RBM: RIDGE BEAM | F.J.: FLOOR JOIST |
| G.B. GRADE BEAM | HBM: HEADER BEAM | |
| T.B. TIE BEAM | | |
| G GRADE | | |

- A. NAILS ARE SMOOTH-COMMON, BOX OR DEFORMED SHANKS EXCEPT WHERE OTHERWISE STATED. NAILS USED FOR FRAMING AND SHEATHING CONNECTIONS SHALL HAVE MINIMUM AVERAGE BENDING YIELD STRENGTHS AS SHOWN: 80 KSI FOR SHANK DIAMETER OF 0.192 INCH (20d COMMON NAIL), 90 KSI FOR SHANK DIAMETERS LARGER THAN 0.142 INCH BUT NOT LARGER THAN 0.177 INCH, AND 100 KSI FOR SHANK DIAMETERS OF 0.142 INCH OR LESS.
- B. STAPLES ARE 16 GAGE WIRE AND HAVE A MINIMUM 7/16-INCH OR DIAMETER CROWN WIDTH.
- C. NAILS SHALL BE SPACED AT NOT MORE THAN 6 INCHES ON CENTER AT ALL SUPPORTS WHERE SPANS ARE 48 INCHES OR GREATER.
- D. FOUR-FOOT BY 8-FOOT OR 4-FOOT BY 9-FOOT PANELS SHALL BE APPLIED VERTICALLY.
- E. SPACING OF FASTENERS NOT INCLUDED IN THIS TABLE SHALL BE BASED ON TABLE R602.3(2).
- F. WHERE THE ULTIMATE DESIGN WIND SPEED IS 130 mph OR LESS, NAILS SHALL, FOR WOOD STRUCTURAL PANEL ROOF SHEATHING TO GABLE END WALL FRAMING SHALL BE 9 INCHES CENTER, WHERE THE ULTIMATE WIND SPEED IS GREATER THAN 130mph,NAILS FOR ATTACHING PANEL ROOF SHEATHING TO INTERMEDIATE SUPPORT SHALL BE SPACED 6 INCHES ON CENTER FOR MINIMUM 48-INCH DISTANCE FROM RIDGES, EAVES AND GABLE END WALLS * 4 INCHES ON CENTER TO GABLE EN WALL FRAMING.
- G. GYPSUM SHEATHING SHALL CONFORM TO ASTM C 1396 AND SHALL BE INSTALLED IN ACCORDANCE WITH GA 253. FIBERBOARD SHEATHING SHALL CONFORM TO ASTM C 208.
- H. SPACING OF FASTENERS ON FLOOR SHEATHING PANEL EDGES APPLIES TO PANEL EDGES SUPPORTED BY FRAMING MEMBERS AND REQUIRED BLOCKING AND AT ALL FLOOR PERIMETERS ONLY. SPACING OF FASTENERS ON ROOF SHEATHING PANEL EDGES APPLIES TO PANEL EDGES SUPPORTED BY FRAMING MEMBERS AND REQUIRED BLOCKING. BLOCKING OF ROOF OR FLOOR SHEATHING PANEL EDGES PERPENDICULAR TO THE FRAMING MEMBERS NEED NOT BE PROVIDED EXCEPT AS REQUIRED BY OTHER PROVISIONS OF THIS CODE. FLOOR PERIMETER SHALL BE SUPPORTED BY FRAMING MEMBERS OR SOLID BLOCKING.
- I. WHERE A RAFTER IS FASTENED TO AN ADJACENT PARALLEL CEILING JOIST IN ACCORDANCE WITH THIS SCHEDULE, PROVIDE TWO TOE NAILS ON ONE SIDE OF THE RAFTER AND TWO NAILS FROM THE CEILING JOIST TO TOP PLATE IN ACCORDANCE WITH THIS SCHEDULE. THE TOE NAIL ON THE OPPOSITE SIDE OF THE RAFTER SHALL NOT BE REQUIRED.

STRUCTURAL STEEL

1.STRUCTURAL STEEL SHALL CONFORM WITH ASTM A-36 UNLESS NOTED OTHERWISE ON THE PLANS.

2.FABRICATION, ERECTION AND MATERIALS SHALL CONFORM WITH THE LATEST EDITION OF THE AISC SPECIFICATION FOR THE DESIGN FABRICATION AND ERECTION OF STRUCTURAL STEEL FOR BUILDINGS.

3. ALL STRUCTURAL STEEL SHALL BE ERECTED PLUMB AND TRUE TO LINE. TEMPORARY BRACING SHALL BE INSTALLED AND SHALL BE LEFT IN PLACE UNTIL THE PERMANENT STRUCTURAL SYSTEM IS PROVIDING SUPPORT.

4.PLACE NON-SHRINK GROUT UNDER ALL BASE PLATES OR BEARINGS BEFORE ADDING VERTICAL LOADS.

5.AT WOOD TO STEEL PARALLEL CONTACTS, BOLT WOOD TO STEEL WITH 1/2" DIAMETER BOLTS AT A MAXIMUM SPACING OF 36 INCHES CENTER TO CENTER UNLESS OTHERWISE NOTED ON PLANS.

6.ALL CONNECTIONS SHALL USE THE STANDARD AISC GAGE AND PITCH, A307 BOLTS UNLESS OTHERWISE NOTED ON PLANS.

7.HOLES FOR UNFINISHED BOLTS SHALL BE OF THE SAME NOMINAL DIAMETER AS THE BOLT PLUS 1/16TH".

8.WELDING SHALL BE DONE BY THE ELECTRIC ARC PROCESS IN ACCORDANCE WITH THE AMERICAN WELDING SOCIETY STANDARDS, USING ONLY CERTIFIED WELDERS. ALL BUTT WELDS SHALL HAVE COMPLETE PENETRATION.

9.ALL EXPOSED BUTT WELDS SHALL BE GROUND SMOOTH.

10.WRAP ANY STRUCTURAL STEEL TO BE EMBEDDED IN CONCRETE WITH WELDED WIRE FABRIC. DO NOT PAINT ANY STEEL TO BE EMBEDDED IN CONCRETE. DRILL EMBEDDED STEEL COLUMNS AND BEAMS TO PASS ANY CONTINUOUS REINFORCING.

11.ALL STRUCTURAL STEEL TO RECEIVE ONE COAT OF SHOP PRIMER AFTER FABRICATION.

12.ALL METAL STUDS, JOISTS, TRACKS OR PLATES SHALL BE "WESTERN METAL LATH COMPANY" PRODUCTS AS SPECIFIED IN THEIR LATEST CATALOG OR AN APPROVED EQUAL. METAL STUD WALLS SHALL BE BLOCKED AT ALL CEILING LEVELS.

CONCRETE

- ALL CONCRETE SHALL MEET THE FOLLOWING MINIMUM SPECIFICATIONS: DESIGN STRENGTH AT 28 DAYS 2500 PSI U.O.N. CEMENT CONTENT SHALL BE A MINIMUM OF 5 SACKS PER CUBIC YARD FOR 1" - 1 1/2" MAXIMUM AGGREGATE SIZE. MAXIMUM SLUMP SHALL BE 4 INCHES. AGGREGATE SIZE SHALL BE COMPATIBLE WITH POURING, PLACING AND FINISHING CONDITIONS.
- ALL CONCRETE SHALL CONFORM WITH REQUIREMENTS OF THE LATEST EDITION OF THE ACI CODE.
- CEMENT SHALL CONFORM TO ASIM C-150 TYPE 1 OR 2.
- CONCRETE AGGREGATES SHALL CONFORM TO ASIM C-33.
- REMOVE ALL DEBRIS FROM THE FORMS BEFORE POURING ANY CONCRETE. NO WOOD FORM SPREADERS OR WOOD STAKES SHALL BE USED IN AREAS TO BE POURED WITH CONCRETE.
- ALL FORM WORK SHALL REMAIN IN PLACE FOR THE PERIODS OF TIME SPECIFIED IN THE ACI CODE MINIMUM.
- ALL CONCRETE SHALL BE CURED BY AN APPROVED METHOD.
- FOLLOW ALL ACI RECOMMENDATIONS FOR PLACING AND CURING CONCRETE DURING HOT OR COLD WEATHER CONDITIONS.
- ALL CONCRETE SHALL BE MOISTURE RESISTANT AND HAVE "XYPEX" ADDITIVE

CONCRETE REINFORCING

- REINFORCING STEEL SHALL CONFORM TO ASTM A615 GRADE 60 FOR #5 AND LARGER BARS; GRADE 40 FOR #4 AND SMALLER.
- REINFORCING STEEL SHALL BE FABRICATED ACCORDING TO THE "MANUAL OF STANDARD PRACTICE FOR REINFORCED CONCRETE CONSTRUCTION".
- REINFORCING DOWELS, BOLTS, ANCHORS AND OTHER ITEMS TO BE EMBEDDED IN CONCRETE SHALL BE SECURELY POSITIONED BEFORE PLACING CONCRETE.
- ALL REBARS TO BE WELDED SHALL BE CONTINUOUSLY INSPECTED BY A QUALIFIED LABORATORY. CONTRACTOR MUST FURNISH TO THE LABORATORY MILL CERTIFICATE SHOWING CHEMICAL ANALYSIS. ALL PREHEATING AND WELDING SHALL BE DONE IN ACCORDANCE WITH AWS STANDARDS.
- CONCRETE COVERAGE SHALL BE FROM THE FACE OF THE BAR AND SHALL DENOTE CLEAR COVERAGE. THE FOLLOWING MINIMUM COVERAGE SHALL BE OBSERVED:
CONCRETE POURED AGAINST EARTH -3"
CONCRETE POURED IN FORMS AND EXPOSED TO EARTH OR WEATHER -2"
BARS IN BEAMS OR COLUMNS -2"
BARS IN WALLS OR INTERIOR FACE -3/4"
BARS IN INTERIOR SLABS -3/4"
- ALL BARS SHOWN CONTINUOUS IN PLANS SHALL HAVE IF SPLICED A MINIMUM SPLICE LENGTH OF 40 X REBAR DIAMETER.

PIPES AT CONCRETE FOUNDATIONS

ALL PIPE SHALL BE ENGAGED IN SLEEVES. PIPES CLEAR SLEEVES BY 1/2". CAULK WITH PLASTIC MATERIAL. IF PIPE IS IN PLACE PRIOR TO POURING CONCRETE, WRAP PIPE WITH 1" GLASS WOOL. STEP FOOTING IF PIPE PASSES BELOW OR IN SPREAD FOOTING PORTION OF FOUNDATION. NO DIGGING IS ALLOWED FOR PIPE TRENCH PARALLEL TO FOOTING BELOW LINES INDICATED.

FOUNDATION DESIGN ASSUMPTIONS:

- THE FOLLOWING ASSUMPTIONS SHALL BE FIELD-CONFIRMED AND VALIDATED BY A CALIFORNIA PROFESSIONAL GEO-TECHNICAL ENGINEER PRIOR TO ANY CONSTRUCTION ACTIVITY:
- CONSERVATIVELY (SEE FOUNDATION PLAN) CONSIDER OC SPACING OF 6.25 FT. TO BE RESISTED BY 18" DIA PIERS (TRIBUTARY WIDTH FOR EACH PIER)
 - CONSERVATIVELY (SEE BUILDING SECTION) CONSIDER HEIGHT OF SOIL TO BE RETAINED BY INTERIOR SOIL PIERS 6.0 FT
 - ACTIVE SOIL PRESSURE 60. PSF / FT DEPTH.
 - PASSIVE SOIL RESISTANCE 300. PSF / FT OF SOIL DEPTH STARTING 4. FT. BELOW BOTTOM OF RETAINED SOIL. (10.FT.BELOW EXISTING RETAINED GRADE).
 - PASSIVE RESISTANCE ACTS ON 2 X TIMES THE PIER DIAMETER.
 - PIERS SHALL HAVE 10. FT. MINIMUM EMBEDMENT INTO BEDROCK.
 - ANY BACKFILL BEHIND RETAINING WALLS OR GRADE BEAMS SHALL BE COMPACTED TO 90% MINIMUM.
 - SUB DRAIN AND ITS OUTLET DESIGN TO BE PROVIDED BY OTHERS AND APPROVED PRIOR TO ANY CONSTRUCTION ACTIVITY.

FOUNDATION EXECUTION PHASES:-

- PHASE 1: ALL PIERS AND THEIR CONNECTION TO THE EXISTING FOUNDATION (DOWELED) AND THE BEAM CONNECTING THE PIERS.
- PHASE 2: DEMOLISH THE REQUESTED LENGTH OF THE EXISTING CROSS GRADE BEAM, 7 DAYS MINIMUM TIME SPAN SHOULD BE SEPARATE BETWEEN PHASE 1 AND 2.
- PHASE 3: RECONSTRUCTION OF EXISTING AND NEW CROSS GRADE BEAMS.

NOTES OF CONSTRUCTION SEQUENCE, SRFACE WATER DRAINAGE, AND DIRT SPOILS

- CONSTRUCTION SHALL FOLLOW THE FOLLOWING SEQUENCE:
- FIRST THE NEW PIERS (FOUR PIERS), HAUNCHES, AND NEW GRADE BEAMS ALONG THE WESTERN EXTERIOR SIDE OF THE HOUSE
- SECOND THE NEW LOWER GRADE BEAM IN THE CRAWL SPACE 4' EAST OF THE WESTERN EXTERIOR SIDE
- THIRD THE NEW UPPER GRADE BEAM IN THE CRAWL SPACE INCLUDING:
- (a) THE NEW FOUNDATION ALONG THE NORTH EXTERIOR AND THE SOUTH EXTERIOR SIDES
 - (b) THE REROUTING OF THE EXISTING INTERIOR TIE BEAM
- FOURTH USING THE NEW LOWER GRADE BEAM IN THE CRAWL SPACE, SHORE UP THE EXISTING FRAMING; THE MAIN BEAMS IN THE EXISTING LOWER FLOOR FRAMING; THEN CONSTRUCT THE NEW FRAMING IN THE EXISTING WESTERN EXTERIOR WALL.

- CONSTRUCTION SHALL COMPLY WITH ALL RECOMMENDATION OF HALLENBECK / ALLWEST REPORT 7745 GP DATED 09-25-17 PERTAINING TO THIS PROJECT INCLUDING:
- PROPER COLLECT-AND-CONVEY OF SURFACE DRAINAGE WATER TO THE GRIZZLY PEAK GUTTER.
 - PROPER OFF-SITE DISPOSAL OF THE EXCAVATED SOIL SPOILS

SHEAR WALL SCHEDULE																		
TYPE	ALLOW. SHEAR (LB/FT)	MIN. FRAMING WIDTH (Nom.)				PLYWOOD			SILL BOLTS (SB)	SOLE PLATE ATTACHMENT		MIN.WIDTH FMG BELOW SHEAR WALL	HOLD DOWN HARDWARE			TENSION TIES (TT)		
		ABUTTING PANEL EDGES	INTERMED. EDGES	SILL PLATE	SOLE PLATE	PLYWOOD SHEATHING	EDGE NAILING (EN)	FIELD NAILING (FN)		NAILING (SPN)	LAG BOLTING (SPLB)		HOLD DOWNS (PHD)	SSTB BOLT	HOLD DOWN ANCHOR BOLT		HD ANCHOR BOLT EMBED.	TIE STRAPS (TS)
▲	-	2X	2X	2X	2X	15/32"	10d @ 4"	10d @ 8"	5/8" @ 32"	16d @ 6"	1/4" X 6" @ 12"	2X	HDU2	SSTB20	5/8 X 16"	12"	ST6236	HTT16
▲	-	3X	2X	3X	3X	15/32"	10d @ 3"	10d @ 6"	5/8" @ 16"	16d @ 4"	1/4" X 6" @ 12"	3X	LSTDH8	SSTB20	5/8 X 16"	12"	ST6236	HTT16

- NOTE:
- ALL NAILS SHALL BE COMMON WIRE NAILS.
 - USE FULL SIZE SHEATHING PANELS WHERE POSSIBLE. MINIMUM PANEL DIMENSION IS 2'-0".
 - RE-TIGHTEN ALL HOLD DOWN AND TENSION TIE BOLTS JUST PRIOR TO CLOSING-UP WALL.
 - GUN NAILING SHALL NOT BREAK THE FACE PILES OF THE SHEATHING.
 - INSTALL ALL SILL BOLTS WITH 3" X 3" 0.229" MINIMUM PLATE WASHERS (SIMPSON BP SERIES OR EQUAL).
 - GALVANIZED NAILS, WHERE USED, SHALL BE HOT-DIPPED OR TUMBLER.
 - SIMPSON HOLD DOWN TO CONCRETE FOUNDATION, 6" MAX. FROM ENDS OF SHEAR WALLS U.O.N.
 - SIMPSON VERTICAL STRAP CENTRED AT MIDDEPTH OF SECOND FLOOR JOISTS, LOCATED 6" MAX. FROM ENDS OF SHEAR WALLS U.O.N.

DESIGN CRITERIA

ROOF:
DEAD LOAD 10 psf
LIVE LOAD 20 psf

WIND SPEED MRI-50YRS: 74 MPH

FLOOR:
DEAD LOAD 10 psf
LIVE LOAD 40 psf

SEISMIC COEFF: Sds=1.545

SPECIAL INSPECTIONS / CONSTRUCTION OBSERVATION:

- THE CONTRACTOR SHALL HAVE THE ENGINEER OF RECORD PROVIDE CONSTRUCTION OBSERVATION FOR
- REBAR PLACEMENT
 - REBAR DOWELING
 - FRAMING SHEAR WALL NAILING
 - ANCHOR BOLTS AND TIE DOWN HARDWARE
 - VISUAL INSPECTION OF MOMENT FRAME WELDS

GENERAL NOTES

1. ALL CONSTRUCTION SHALL CONFORM WITH APPLICABLE BUILDING CODES AND REGULATIONS.

2. DETAILS AND NOTES SHOWN ON THIS SHEET ARE TYPICAL AND SHALL APPLY UNLESS OTHERWISE SHOWN OR NOTED. DETAILS OF CONSTRUCTION NOT FULLY SHOWN SHALL BE OF THE SAME NATURE SHOWN FOR SIMILAR CONDITIONS. THE CONTRACTOR SHALL BE RESPONSIBLE TO VERIFY ALL DIMENSIONS, ELEVATIONS, PROPERTY LINES AND OTHER RELATED ITEMS ON THIS JOB.

3. IT IS THE CONTRACTOR'S RESPONSIBILITY TO COMPLY WITH THE PERTINENT SECTIONS, AS THEY APPLY TO THIS PROJECT OF THE "CONSTRUCTION SAFETY ORDERS" ISSUED BY THE STATE OF CALIFORNIA AND ALL OSHA REQUIREMENTS. THE ARCHITECT, THE ENGINEER AND THE OWNER DO NOT ACCEPT ANY RESPONSIBILITY FOR THE CONTRACTOR'S FAILURE TO COMPLY WITH THESE REQUIREMENTS.

4. THE CONTRACTOR SHALL BE RESPONSIBLE FOR ADEQUATE DESIGN AND CONSTRUCTION OF ALL FORMS, BRACING AND SHORING REQUIRED. THE CONTRACTOR SHALL PROVIDE ADEQUATE STAYS AND BRACING OF ALL FRAMING UNTIL ALL ELEMENTS OF DESIGN HAVE BEEN INCORPORATED IN THE PROJECT. THE CONTRACTOR SHALL BE RESPONSIBLE TO HAVE SHOP DRAWINGS PREPARED PRIOR TO FABRICATION FOR ALL PREFABRICATED MATERIALS OF CONSTRUCTION. SHOP DRAWINGS SHALL SERVE TO DEMONSTRATE THE CONTRACTOR'S UNDERSTANDING OF THE DESIGN CONCEPT, BY INDICATING WHICH MATERIALS HE INTENDS TO FURNISH AND INSTALL AND BY DETAILING THE FABRICATION AND METHOD OF INSTALLATION. CONTRACTOR SHALL SUBMIT ALL SHOP DRAWINGS FOR REVIEW BY THE ENGINEER AND SHALL INCORPORATE ANY COMMENTS INTO THE DRAWINGS PRIOR TO FABRICATION. CONTRACTOR AGREES THAT SHOP DRAWINGS PROCESSED BY THE ENGINEER ARE NOT CHANGE ORDERS.

WOOD

1. ALL STRUCTURAL WOOD SHALL CONFORM WITH THE LATEST EDITION OF THE FOLLOWING SPECIFICATIONS:
- DOUGLAS FIR..... WEST COAST LUMBERMEN'S ASSOCIATION GRADING RULES.
 - REDWOOD..... CALIFORNIA REDWOOD ASSOCIATION GRADING RULES.
 - STRUCTURAL PLYWOOD..... U.S. PRODUCT STANDARD PS-1 FOR SOFTWOOD PLYWOOD
2. MINIMUM GRADES FOR STRUCTURAL LUMBER SHALL BE:
- DOUGLAS FIR #2 FOR 2X MEMBERS / DOUGLAS FIR #1 FOR OTHERS
 - GLUED LAMINATED MEMBERS - COMBINATION # 24F-V4
 - STRUCTURAL PLYWOOD APA C-D EXTERIOR GLUE.
3. PROVIDE SOLID BLOCKING BETWEEN JOISTS OR RAFTERS AT ALL SUPPORTS.
4. PROVIDE SOLID BLOCKING FOR ALL ROOF RAFTERS OR FLOOR JOISTS THAT ARE 9 OR MORE INCHES DEEP. AT 8 FEET ON CENTER MAXIMUM.
5. INSTALL 2X JOIST UNDER AND PARALLEL TO PARTITIONS.
6. CUTTING OF WOOD JOISTS SHALL BE LIMITED TO CUTS AND BORED HOLES NOT DEEPER THAN ONE-FIFTH THE JOIST DEPTH FROM THE TOP, AND LOCATED NOT FARTHER FROM POINTS OF BEARING THAN THREE TIMES THE JOIST DEPTH.
7. ALL WOOD FRAMING MEMBERS SHALL EITHER BEAR ON PLATES, BEAMS, POSTS OR BE SUPPORTED IN JOISTS HANGERS.
8. ALL LIGHT GAGE METAL CONNECTORS FOR WOOD CONSTRUCTION SHALL BE SIMPSON "STRONG-TIE" PRODUCTS AS SPECIFIED IN THEIR LATEST CATALOG OR AN APPROVED EQUAL.
9. HOLES FOR BOLTS IN WOOD SHALL BE BORED WITH A BIT OF THE SAME NOMINAL DIAMETER AS THE BOLT PLUS 1/16TH OF AN INCH. HOLES FOR LAG SCREWS SHALL BE FIRST BORED TO THE SAME NOMINAL DIAMETER AND DEPTH AS THE SHANK AND THE REMAINDER OF THE HOLE SHALL BE BORED AT NO MORE THAN THE DIAMETER OF THE ROOT OF THE THREADS.
10. ALL BOLTS, EXPANSION ANCHORS AND LAG SCREWS SHALL BE PROVIDED WITH METAL WASHERS AND SHALL BE TIGHTENED ON INSTALLATION AND RE-TIGHTENED BEFORE CLOSING IN OR COMPLETION OF THE JOB.
11. BLOCK STRUCTURAL PLYWOOD JOINTS WITH 2X4 FLAT BLOCKING.
12. ALL NAILS FOR STRUCTURAL WORK SHALL BE COMMON WIRE NAILS.
13. NAILING SHALL SATISFY ALL MINIMUM C.B.C. 2016 CODE REQUIREMENTS.

14. ALL WOOD IN CONTACT WITH CONCRETE SHALL BE PRESSURE TREATED DOUGLAS FIR.

15. FLOOR SHEATHING SHALL BE 3/4" CD, 36/16 PLYWOOD. GLUE AND EDGE NAIL WITH 16d @ 6" AND FIELD NAIL WITH 10d @ 12" U.O.N. ON PLANS.

16. DOUBLE JOISTS UNDER ALL SHEAR WALLS.

17. LOCATE ALL POSTS DIRECTLY OVER BEAMS OR JOISTS BELOW.

18. POSTS AT EXTERIOR WALLS SHALL BE 6X WIDTH OF BEAMS; AND POSTS AT INTERIOR WALLS SHALL BE 4X WIDTH OF BEAMS U.O.N. ON THE PLANS.

19. ALL SILL PLATE ANCHOR BOLTS SHALL HAVE 5/8" MIN. DIAMETER U.O.N., SHALL BE SPACED AT 4'-0" MAX. U.O.N. ON THE PLANS, SHALL HAVE 7" MIN. EMBEDMENT INTO THE CONCRETE, AND SHALL HAVE 3"X3"X0.229" THICK MINIMUM SIZE WASHERS GALVANIZED.

20. ALL BEAMS POST CONNECTIONS ARE CC TYPE. SIMPSON CONNECTORS.

21. CRIPPLE WALL SHALL BE MINIMUM 2X6 STUDS U.O.N.

TYPICAL FLOOR SHEATHING

TYPICAL STRUCTURAL PLYWOOD PANEL LAYOUT WITH FACE GRAIN PERPENDICULAR TO FRAMING. STAGGER PLYWOOD SHEETS. NAIL WITH 16d NAILS AT 6" CC. OR AS OTHERWISE INDICATED ON THE DRAWINGS, AT ALL PANEL EDGES. ALL DIAPHRAGM PANELS EDGES SHALL BE BLOCKED.

FOUNDATIONS

ALL FOOTINGS NOT FORMED SHALL BE POURED INTO NEAT EXCAVATIONS. MEASURES SHALL BE TAKEN TO PREVENT SLOUGHING OF SOIL INTO THE FOOTING EXCAVATION PRIOR TO AND DURING THE PLACING OF CONCRETE.

JEDCO
CONSULTING ENGINEERS

1000 CONTRA COSTA DR.,
EL CERRITO, CA 94530
PHONE: (510) 703 0095

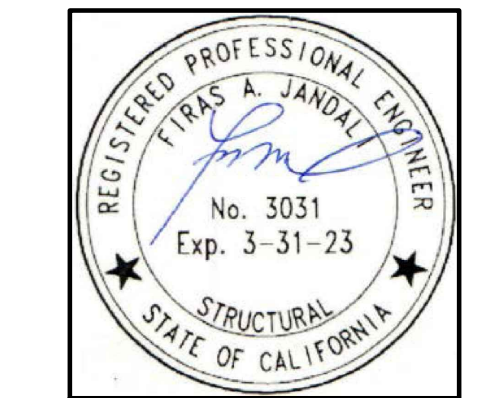

ENGINEER

FIRAS JANDALI

SHEET NOTES

PLAN KEY

DRAWING REVISIONS
DATE DESCRIP. TAG

SCALE

SHEET TITLE

STRUCTURAL NOTES

SHEET NUMBER

S1

PROJECT/ADDRESS

ADDITION OF NEW MOMENT
STEEL FRAME & VOLUNTARY
SEISMIC UPGRADE

803 DELAWARE STREET,
BERKELEY, CA

DRAWN BY

RANPEL

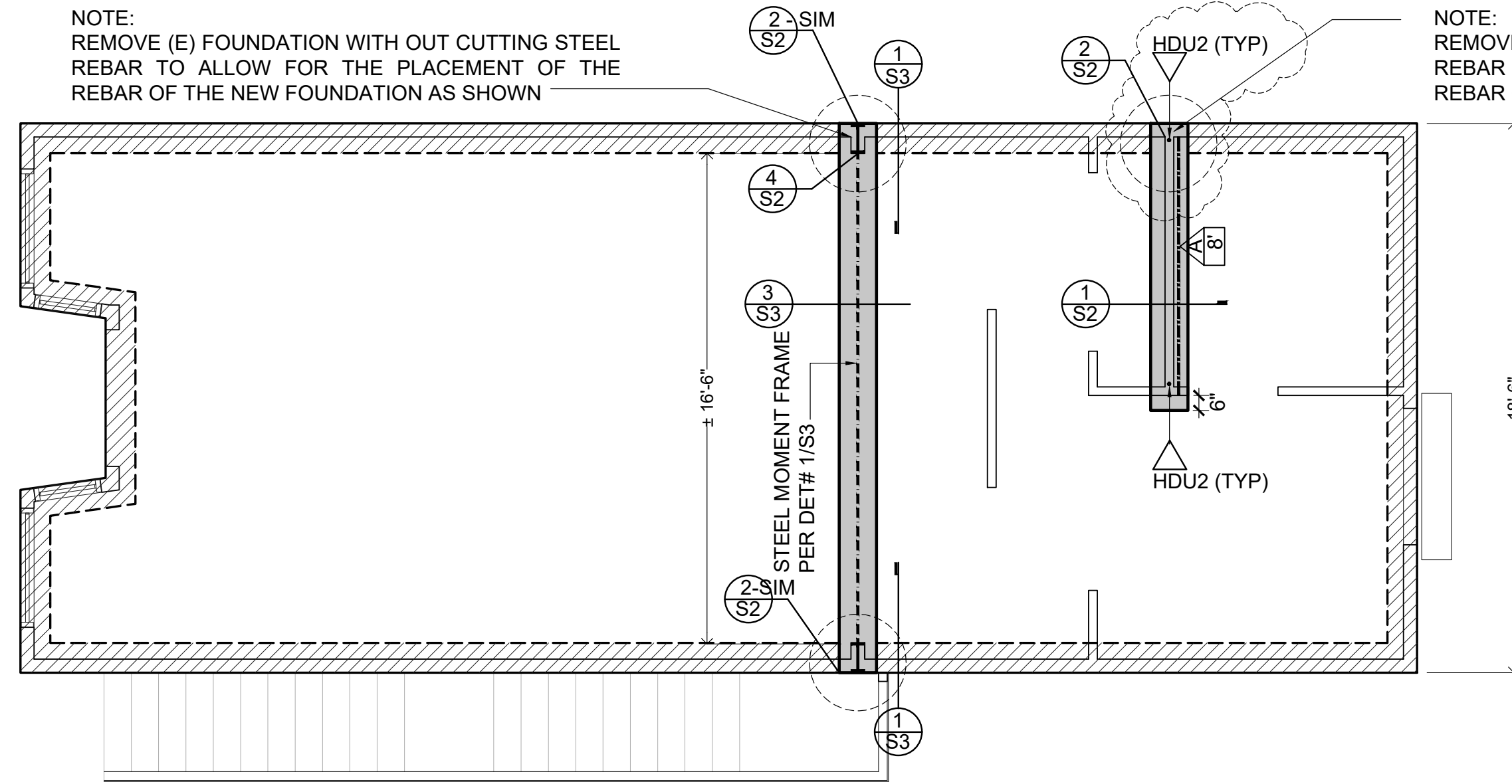

NEW FOUNDATION / SHEAR WALLS AND MOMENT FRAMING PLAN

LEGEND
 INDICATED EXISTING FOOTING TO REMAIN AS IS
 INDICATED NEW FOOTING

SC : 1/4" = 1

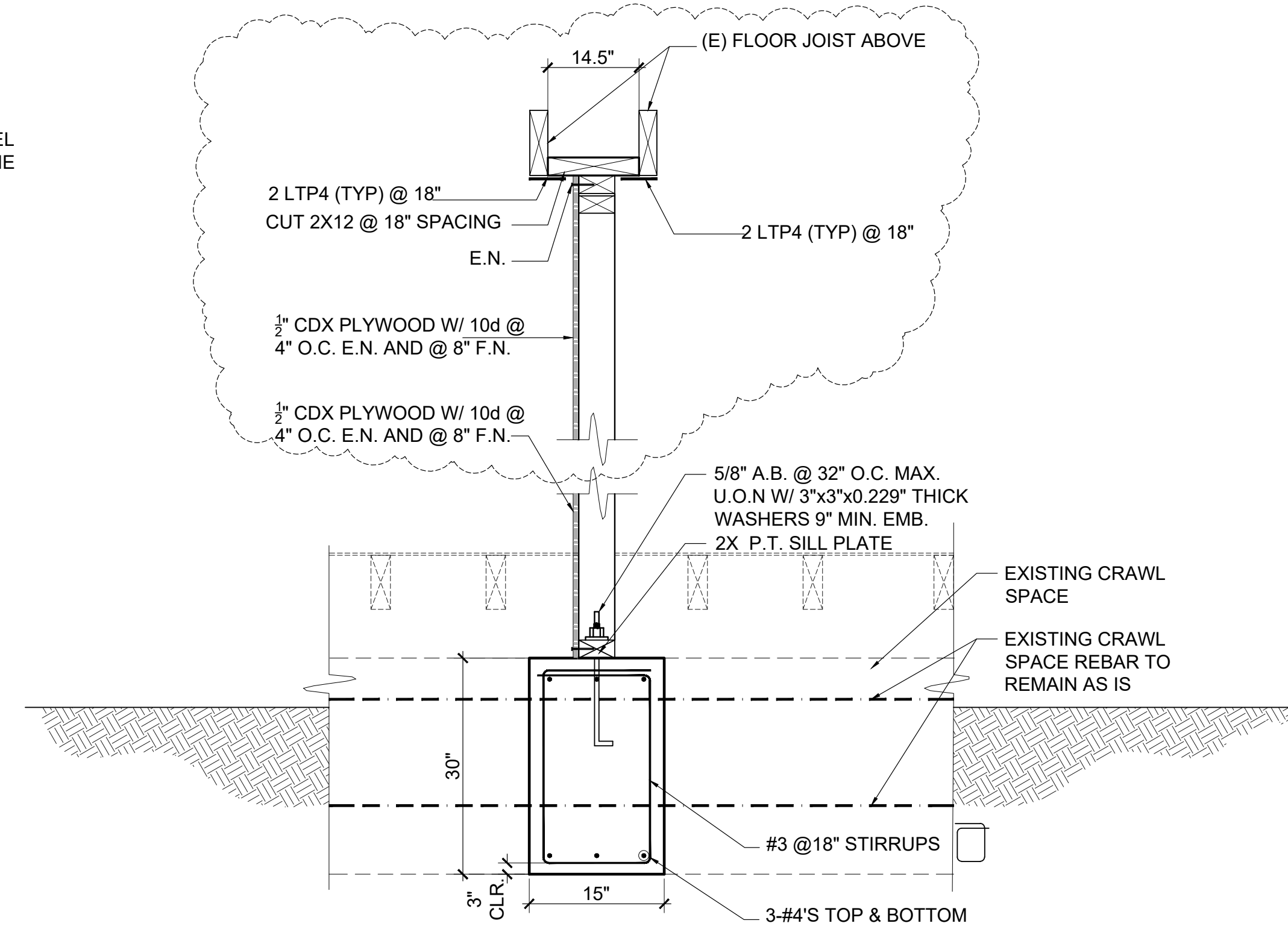

1 NEW FOUNDATION SECTION DETAIL, TYP.
NOT TO SCALE

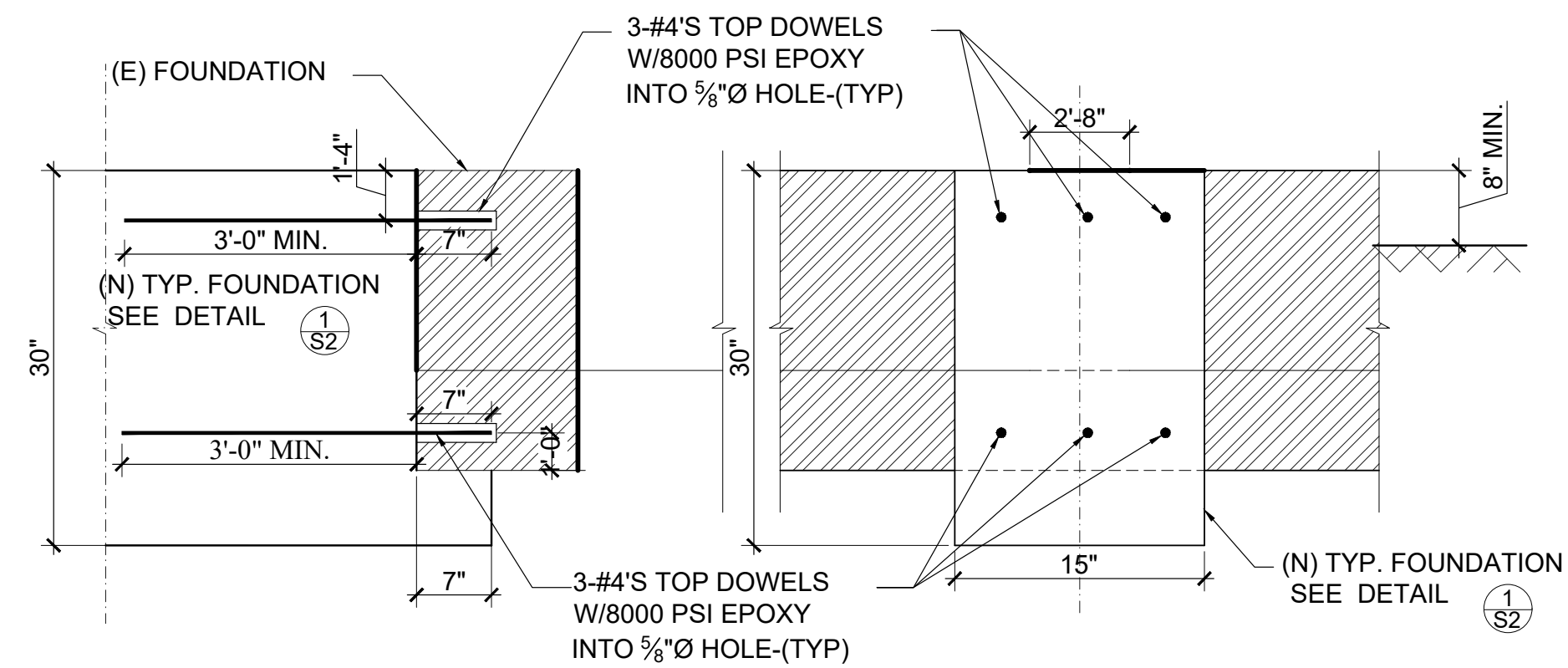

2 OPTIONAL DETAIL IF EXISTING REBAR IS CUT
NOT TO SCALE

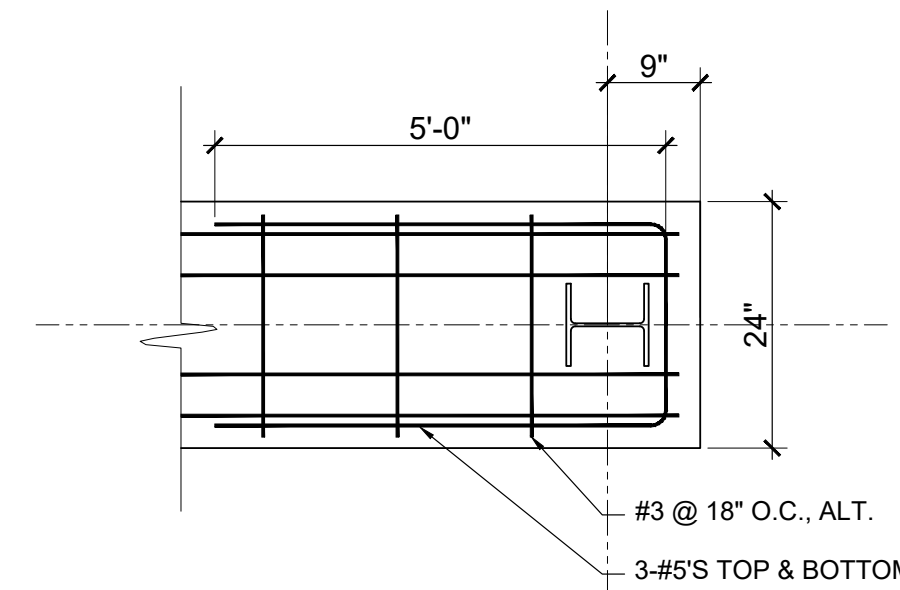

4 STEEL MOMENT FRAME BEAM ASSEMBLY - PLAN
NOT TO SCALE

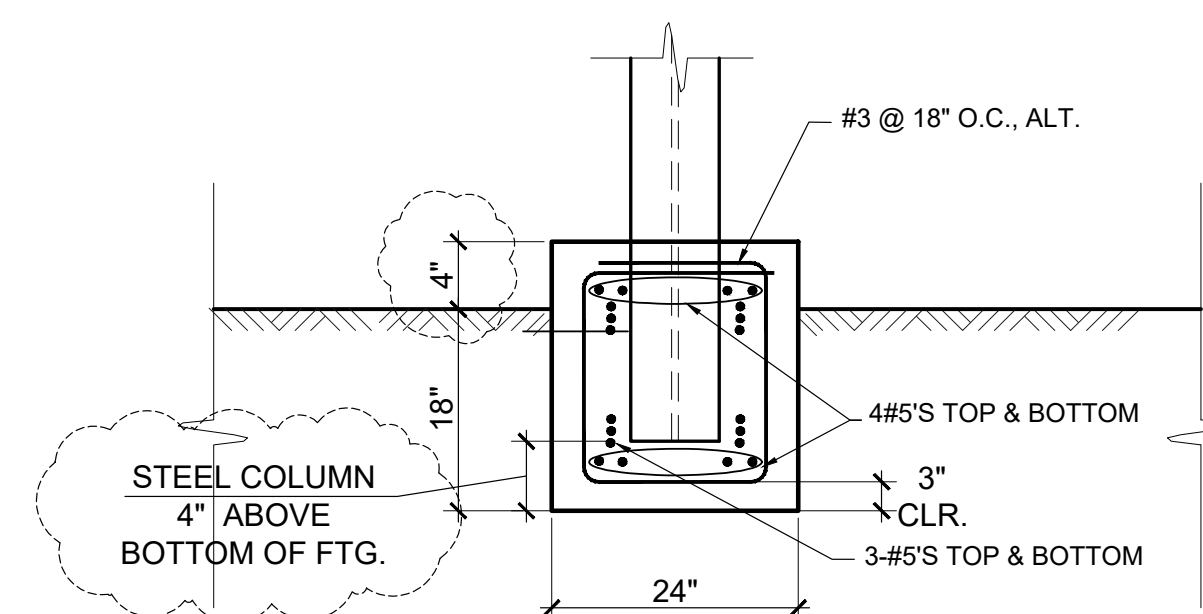

3 STEEL MOMENT FRAME BEAM ASSEMBLY - SECTION
NOT TO SCALE

JEDCO
CONSULTING ENGINEERS
1000 CONTRA COSTA DR.,
EL CERRITO, CA 94530
PHONE: (510) 703 0095



ENGINEER
FIRAS JANDALI

SHEET NOTES

PLAN KEY

DRAWING REVISIONS

DATE

DESCRIP.

TAG

SCALE

SHEET TITLE

FOUNDATION ,
SHEAR WALLS
& FOUNDATION DETAILS

SHEET NUMBER

S2

PROJECT/ADDRESS

803 DELAWARE STREET,
BERKELEY, CA

DRAWN BY

RANPEL

DATE OF PLOT

09-03-2022

ADDITION OF NEW MOMENT
STEEL FRAME & VOLUNTARY
SEISMIC UPGRADE

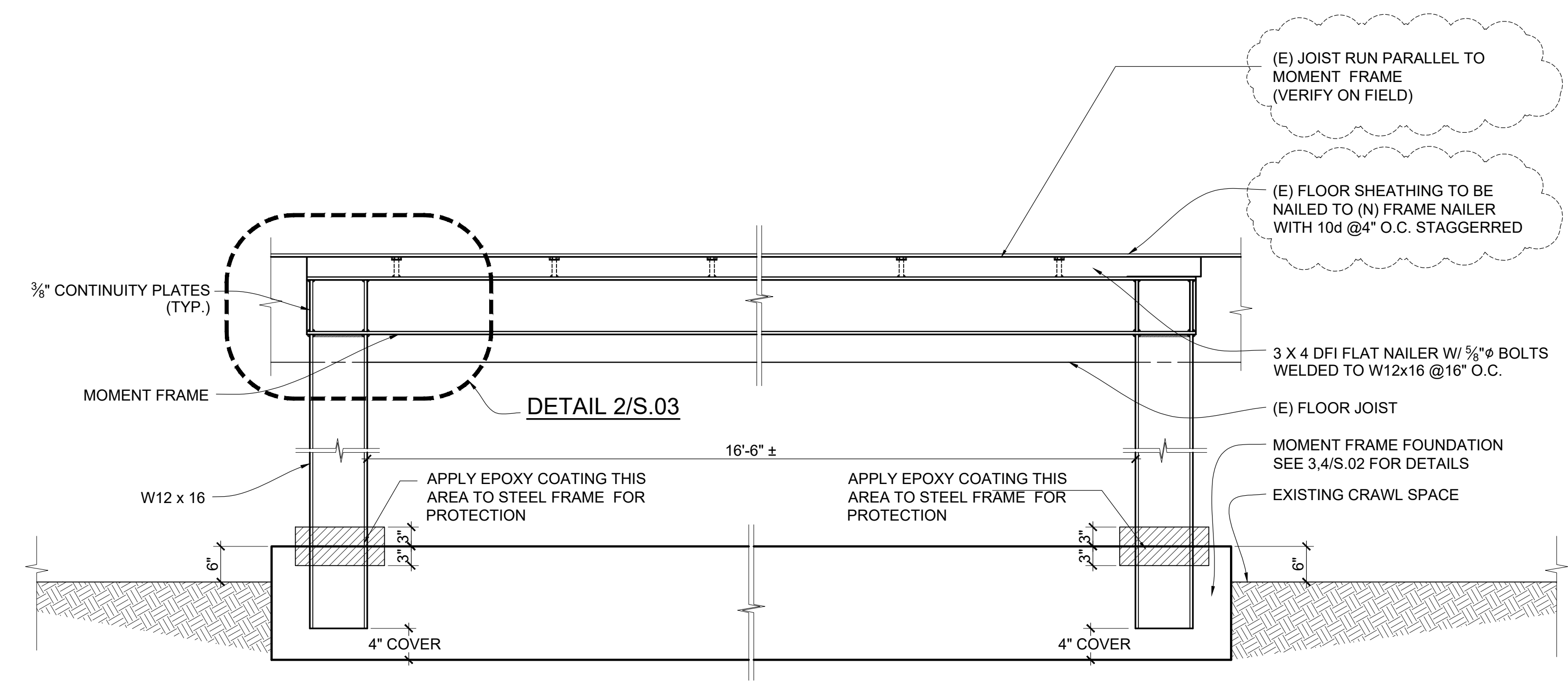

1 STEEL MOMENT FRAME - ELEVATION
NOT TO SCALE

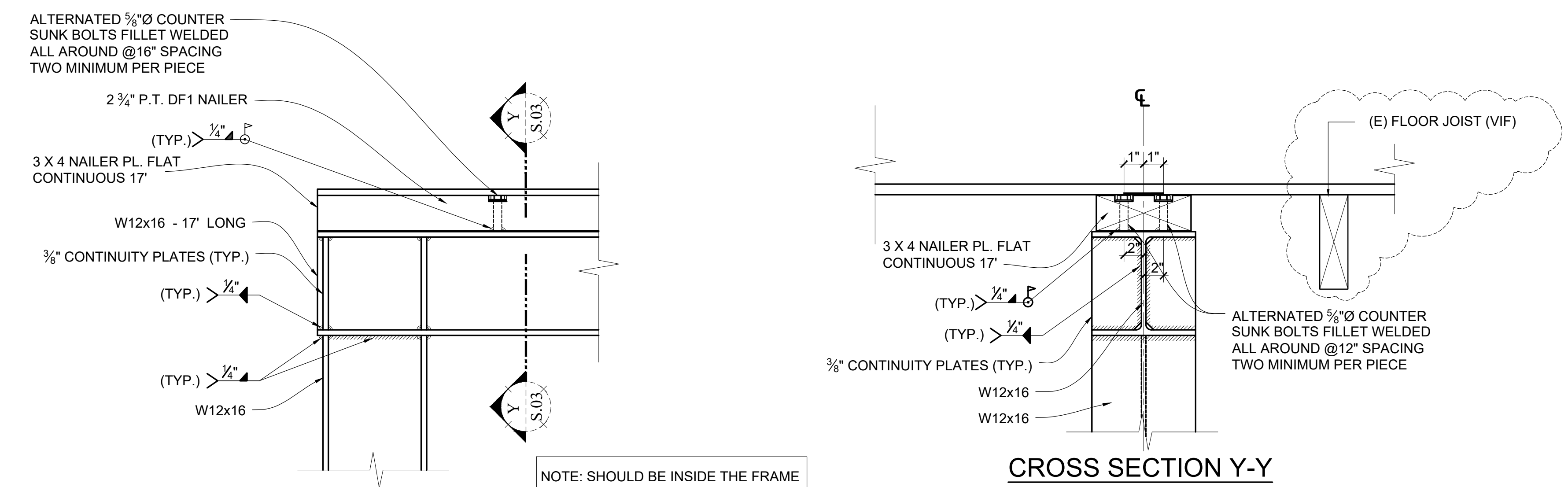

2 PREFABRICATED STEEL MOMENT FRAME - NAILER ASSEMBLY (TYP.)
NOT TO SCALE

JEDCO
CONSULTING ENGINEERS
1000 CONTRA COSTA DR.,
EL CERRITO, CA 94530
PHONE: (510) 703 0095

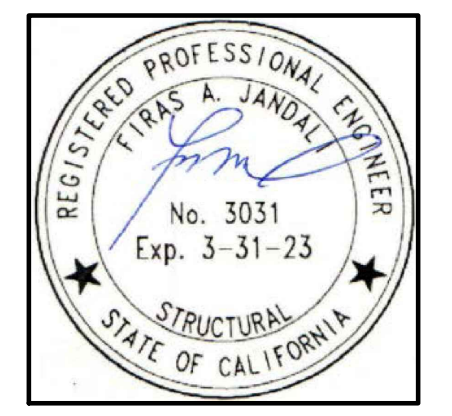

ENGINEER
FIRAS JANDALI

SHEET NOTES

PLAN KEY

DATE	DESCRIP.	TAG

DRAWING REVISIONS

SCALE AS SHOWN

SHEET TITLE
STEEL MOMENT FRAMING DETAILS

SHEET NUMBER
S3

PROJECT/ADDRESS
ADDITION OF NEW MOMENT STEEL FRAME & VOLUNTARY SEISMIC UPGRADE

803 DELAWARE STREET, BERKELEY, CA

DRAWN BY: RANPEL DATE: 09-03-2022